

Model SADPminiEx



Instruction Manual

Alpha Moisture Systems
Alpha House
96 City Road
Bradford
BD8 8ES
England

Tel: +44 1274 733100
Fax: +44 1274 733200
Email: info@amsystems.co.uk
Web: www.amsystems.co.uk
www.dew-point.com

Warranty

Alpha Moisture Systems Ltd. (AMS) warrants the products it manufactures, or distributes, to be free of defects in material and workmanship under normal use and service when operated within the specified design limitations for a period of 24 months from date of initial shipment.

Under this Warranty, AMS will, at its discretion, repair or replace any component that upon examination by AMS or its duly authorized representatives proves to be defective during the warranty period, provided the system is returned to the factory for inspection and repair shipping prepaid.

Improper or unauthorized maintenance, storage, repair, or alteration of any kind by personnel other than AMS, or its duly authorized representatives, may void all warranties. Warranty may also be voided for misuse, neglect, accident, corrosion, and improper installation.

This Warranty is exclusive and in lieu of any and all other warranties of merchantability, fitness for a particular purpose, or any other warranty, expressed or implied, and all other liabilities and obligations on the part of AMS. AMS will not be liable for any other claims or damages, either direct, indirect, or consequential arising out of the use of its products.

Original manuals are prepared in English. Translations in other languages may be available, but in the event of any discrepancy, the English version will be considered as the official version, which is subject to change without notice.

NOTE: Corrosive Gases: The Sensor should not be exposed to corrosive gases (or corrosive contaminants in the gas sample) as these can chemically attack the sensor, impairing calibration accuracy and/or damaging it beyond economic repair. Examples of such gases are mercury (Hg), ammonia (NH₃), chlorine (Cl₂) etc. Strong oxidising agents such as ozone (O₃) should also be prevented from coming into contact with the sensor.

Instruction Manual

For the

SADPminiEx Automatic Dewpoint Hygrometer



1405 SADPminiEx User Manual.doc
Issue 11
26/05/19

Table of Contents

1	GENERAL INFORMATION	1
2	FEATURES	1
2.1	RANGES	2
2.2	CASING	2
3	SAFETY INFORMATION	2
3.1	WARNING	2
3.2	SPECIAL CONDITIONS OF USE - (DENOTED BY THE X AFTER THE CERTIFICATE NUMBER)	2
3.3	PRESSURE EXPOSURE	3
3.4	BATTERY	3
3.4.1	Lithium-Polymer	3
3.4.2	Initial Charging	3
4	INSTALLING THE AIR/GAS SAMPLING SYSTEM	3
4.1	GASES TO AVOID	4
4.2	PIPING INSTALLATION SCHEMATIC	5
4.3	PIPING SCHEMATIC COMPONENT INDEX	5
5	PURGING THE SAMPLE CONNECTION	6
6	USING THE SADPMINIEX TO TAKE A MOISTURE READING	6
6.1	TAKING A MEASUREMENT	6
7	SAMPLING INFORMATION	7
7.1	SAMPLE PIPE	8
7.2	SAMPLE CONDITIONING	8
7.3	PRESSURE AND FLOW CONTROL	8
7.4	PARTICULATE CONTAMINATION	8
7.5	LIQUID CONTAMINATION	9
8	SADPMINIEX INITIAL CONFIGURATION	9
9	THE NORMAL DISPLAY SCREEN	10
10	SADPMINIEX OPERATING PRINCIPLES	10
10.1	NAVIGATING THROUGH MENUS	10
10.2	ENTERING NUMERICAL DATA	10
10.3	ENTERING ALPHANUMERICAL DATA	11
10.4	SECURITY PROTECTION SCREENS	11
11	OPERATING THE SADPMINIEX	11
11.1	THE SETUP MENU	11
11.1.1	Select Units	11
11.1.2	Pressure Calc	12
11.1.3	4-20mA Output (4-20mA and Full Logging versions only)	12
11.1.4	AutoCal	12
11.1.5	SPC (Single point Calibration)	14
11.1.6	Security	15
11.1.7	Time and Date	15
11.1.8	Set Clock	15
11.1.9	Information	16
11.1.10	Temperature	16
11.1.11	Exit	16
11.2	THE LOGGING MENU (FULL LOGGING VERSIONS ONLY)	16
11.2.1	Internal Logging	17
11.2.2	Review Data	17
11.2.3	PC Comms	18
11.2.4	Delete Data	19
11.2.5	Create TAG	19
11.2.6	Edit TAG	19
11.2.7	Delete TAG	19
11.2.8	Printer LOG	20
11.2.9	Unit Address	20
11.2.10	Free Space	20
11.2.11	Exit	21
12	PRESSURE CORRECTION	21

13	BATTERY CURRENT STATUS	21
14	SADPMINIEx 4-20MA	22
14.1	SADPMINIEx 4-20MA CIRCUIT	22
14.2	CALCULATING MAXIMUM OUTPUT LOAD (R_{EXT})	22
15	RS485 COMMUNICATIONS	23
16	SADPMINIEx LOGGING SOFTWARE CABLES AND INTERFACES	23
16.1	RS232 TO RS485 CABLES & INTERFACE.....	23
16.2	USB TO RS485 CABLES & INTERFACE.....	25
17	TECHNICAL DETAILS OF THE RS485\4-20MA CONNECTER (CON066)	26
18	SADPMINI PROTOCOL.....	27
19	INSTRUCTIONS FOR REPLACING DESICCANT IN THE SADPMINIEx	27
20	APPENDIX C – SADPMINIEx SETUP MENU MAP	28
21	APPENDIX D – SADPMINIEx LOGGING MENU MAP	29
22	APPENDIX E – TROUBLE SHOOTING	30
23	APPENDIX F – SADPMINIEx SPECIFICATION.....	31

1 General Information

- The SADPminiEx is a battery powered portable instrument, consisting of an aluminium oxide sensing element and associated printed circuit boards. Also incorporated in the device is LCD indication, membrane keypad, RS485 interface, 4-20mA interface, charger socket and sample inlet and outlet ports.
- Certified as intrinsically safe FTZU 04ATEX0290X

2 Features

Basic SADPminiEx

- 128 x 64 dot Backlit LCD Graphics Display.
- Tactile membrane keypad, coupled with an easy to operate user interface.
- Operates from an internal rechargeable Lithium Polymer battery.
- Battery life in excess of 70 hours* continuous use, from fully charged.
- Full charge time approximately 14 hours. **Only use the Charger supplied with SADPminiEx. CHARGE IN SAFE AREA ONLY**
- 7 selectable moisture units (°C, °F, ppm(V), ppm(W), ppb, g/m³ and lb/MMSCF).
- Pressure compensated moisture readings in 4 selectable units of pressure (psig, barg, kg/cm²g and Kpag).
- Battery life Indicator.
- Built in Automatic Calibration (AutoCal).
- Built in Single Point Calibration (SPC).
- On board Real Time Clock.
- User settable security access.
- Sample gas flow temperature indication.

4-20mA Option *(all the Basic SADPminiEx features plus)*

- 4-20mA Loop Powered output. **FOR USE IN SAFE AREA ONLY**

Full Logging Option *(all the 4-20mA option features plus)*

- Stores up to 16000 data points.
- 20 definable alphanumeric TAG references, including 1 preset.
- Up to 20 blocks of data stored under each TAG reference.
- Review stored data in tabular and graphical form.
- RS485 Serial Communication to dedicated PC software. **FOR USE IN SAFE AREA ONLY**
- Download stored data in CSV format. **FOR USE IN SAFE AREA ONLY**
- Real Time logging to connected PCs. **FOR USE IN SAFE AREA ONLY**
- Thermal printer driver facility. **FOR USE IN SAFE AREA ONLY**

2.1 Ranges

- SADPminiEx - SR -110 to -20°C Dewpoint (-166 to -4°F Dewpoint)
- SADPmini Ex - PL -100 to 0°C Dewpoint (-148 to +32°F Dewpoint)
- SADPmini Ex - RD -80 to -20°C Dewpoint (-112 to -4°F Dewpoint)
- SADPmini Ex - GY -80 to 0°C Dewpoint (-112 to +32°F Dewpoint)
- SADPmini Ex - BL -80 to +20°C Dewpoint (-112 to +68°F Dewpoint)

2.2 Casing

- The SADPminiEx housing is a moulded plastic enclosure with a cast aluminium sample head.
- The instrument is provided as standard with a padded anti-static carrying case with shoulder strap for use in hazardous areas.

3 Safety Information

Read the safety information below, **before use**.

3.1 Warning

The SADPminiEx is Intrinsically Safe. Therefore, it can be used in hazardous areas.

Certification: ATEX –  II 1 G
Ex ia IIC T4 (Ta = - 20°C to +40°C)
Ex ia IIC T3 (Ta = - 20°C to +50°C)

It is the responsibility of the user to ascertain the suitability of the SADPminiEx for use in hazardous areas. Risk assessments should be performed prior to use taking into account the SADPminiEx certifications, the 'x' rating (Light alloy content) of the SADPminiEx, and the location and the gas being monitored etc.

3.2 Special Conditions of Use - (denoted by the X after the certificate number)

- The apparatus contains light alloy parts and must be protected from impact and friction when used and transported in hazardous areas. The apparatus must therefore be carried in the (antistatic) protective carry case supplied when being transported in a hazardous area.
- The ambient temperature Ta = - 20°C to +50°C

3.3 Pressure Exposure

The maximum pressure to which the telescopic measuring head is exposed must not be more than

0.3barg, 4.35psig, 30kpag or 0.3kg/cm²g

Exposing the measuring head to higher pressures may damage the instrument and result in injury to the operator or other personnel in the area

3.4 Battery

3.4.1 Lithium-Polymer

The SADPminiEx contains an encapsulated Lithium-Polymer battery which, to conform to current legislation should always be partially discharged before shipping.

Note: There are no serviceable parts within the encapsulated battery.

3.4.2 Initial Charging

- It is recommended that the SADPminiEx be put on charge overnight when first received, the unit should be turned **OFF** during charging. **Only use the Charger supplied with SADPminiEx**
- To attain maximum battery life the SADPminiEx should always be re-charged at room temperature, with the unit turned **OFF**.
- The battery life (hours of use from a fully charged cell) will reduce when used in cold conditions. * 70 hours is quoted as the expected battery life when used at room temperature.

Note: The 4-20mA output should not be operated while the instrument is charging.

4 Installing the Air/Gas Sampling System

The piping installation schematic diagram (see section 4.1) shows all components, which could be used in a dry gas measurement application although not all the items shown will be required for every installation.

Care should be taken to ensure that the sample presented to the SADPminiEx is not contaminated with any component that will damage, contaminate or affect the SADPminiEx in a way that will impair the unit's accuracy.

It is strongly recommended that the sample should not contain particulate matter, oil, hydrocarbon or any other condensate. If these components contaminate the sample system and/or the measuring sensor, the SADPminiEx response time will be lengthened, although the sensor calibration will not be effected.

The flow rate, although not critical to the sensor measurement, should be low enough to avoid abrasion to the sensor surface without being so low as to extend the SADPminiEx

response time to an unacceptable level. In general, a flow rate of between 5 and 8 litres/min at NTP will give the right balance.

The sensor used in the SADPminiEx is a variable capacitor, which is directly affected by changes in partial pressure of water vapour, and these changes, that are proportional to the dew/frost point temperature, are displayed on the instrument indicator.

pressure of water vapour, and these changes, that are proportional to the dew/frost point temperature, are displayed on the instrument indicator.

4.1 Gases to Avoid

Corrosive Gases: The Sensor should not be exposed to corrosive gases (or corrosive contaminants in the gas sample) as these can chemically attack the sensor, impairing calibration accuracy and/or damaging it beyond economic repair. Examples of such gases are mercury (Hg), ammonia (NH₃), chlorine (Cl₂) etc. Strong oxidising agents such as ozone (O₃) should also be prevented from coming into contact with the sensor.

4.2 Piping installation Schematic

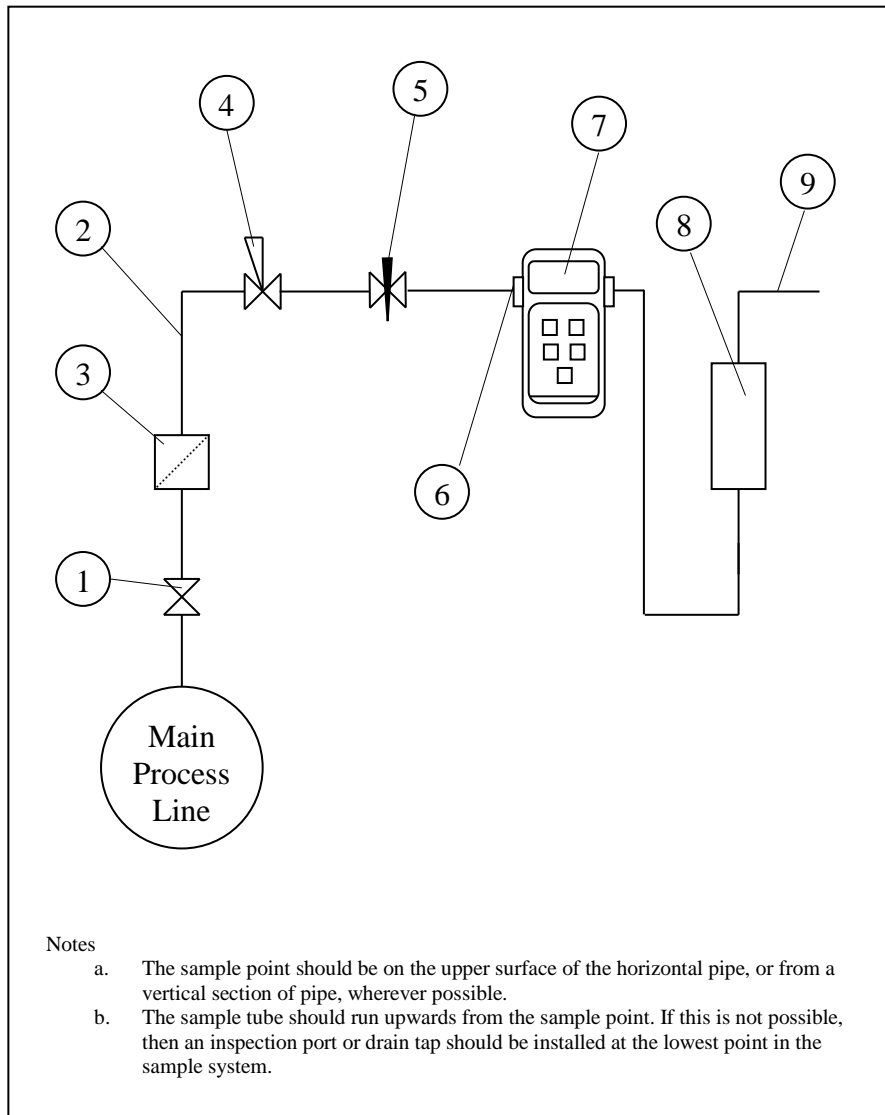

4.3 Piping Schematic Component Index

1. Sample Isolation Valve - This is a recommended item as it allows access to the sample system without interrupting the main process line.
2. Sample Tube – This should be stainless steel for dry air or gas applications but copper or carbon steel can be used where wetter gases are to be measured. If any section of the sample tube must be flexible then PTFE should be used. In most cases, 3mm OD (1/8”) is sufficient as it provides good system response time with minimum flow. 6mm OD (1/4”) tube can be used where pressure drops across the 3mm tube are too high
3. Filter Unit – A filter unit is recommended when the samples are likely to contain particulate matter. If the air/gas sample contains heavy hydrocarbon condensate, the filter must be of the coalescing type with a drain. The filter unit should be positioned as close to the sample point as practical.

4. Pressure Reduction Valve or Pressure Regulator – the sample is measured at atmospheric pressure requiring that valve 4 is fitted to the system.
5. Flow Control Valve.
6. Sample Connection
7. SADPminiEx.
8. Flow Indicator – The recommended sample flow is 5 to 20 L/M.
9. Sample Exhaust – The exhaust is vented to atmosphere or returned to an atmospheric pressure line.

5 Purging the sample connection

Refer to the sample system schematic in section 4.2.

It is advisable to carry out an initial purge of the sample loop, before connecting the SADPminiEx, in order to avoid the possibility of sensor damage on start-up.

Open the sample isolation valve (1) slowly, until a there is a small flow of air/gas at atmospheric pressure from the pressure reduction valve (4) into SADPminiEx line. Allow the air/gas to exhaust through the sample connection (9).

The SADPminiEx is not flow sensitive however the sample flow needs to be enough to purge the sensor head effectively, so anything less than 1 litre/min would mean that the instrument would take too long to settle to a stable reading. The flow should also not be so high that the gas velocity could physically damage the sensor or cause backpressure in the sensor head, so should not exceed about 20 litres/min.

Allow this purge to continue for 2 minutes to remove any residual moisture from the sample pipe work and components. Check that no liquid or particulate contamination, which could damage the sensor, is passing through the sample pipe. Directing the sample onto a piece of white paper (such as a filter paper) will make it easier to see any dust or oil mist in the sample.

6 Using the SADPminiEx to take a Moisture Reading

Refer to the sample system schematic in section 4.2.

The first purpose of the SADPminiEx is to provide a rapid, easy and reliable means of carrying out moisture content measurements, of gases. To ensure rapid response the sensor is kept dry by surrounding the sensor with desiccant in the head assembly when it is not in use.

The SADPminiEx can display moisture readings in any one of six Engineering Units and can also display pressure compensated readings. The SADPminiEx should be setup as required (See The Setup Menu section) before progressing to take sample readings.

6.1 Taking a Measurement

After purging the system to be monitored fit the SADPminiEx sample pipe to the sample connection (6). Allow the gas to purge for a further 2 minutes with the head down.

**SADPminiEx
Head Lowered**



**SADPminiEx
Head Raised**



Restrict the outlet of the SADPminiEx (7) by placing a finger over the sample exhaust (9), so that the pressure of the sample lifts the telescopic head. As soon as the head is fully extended remove the finger, to prevent pressure build up. Pull gently on the head to make sure it is fully extended. If there is not enough pressure to lift the head assembly, assist it by pulling it up; do this very slowly so that ambient air is not drawn in through the outlet. It may help to turn the head to break the “sticktion” be sure to turn clockwise, so as not to loosen the locking ring.

The sensor will respond to the moisture level present in the sampled gas. The displayed moisture value will continue to change until the sensor reaches equilibrium; at which point the displayed value is representative of the moisture level in the sampled gas.

When the test is finished push down the telescopic head fully, turn off the sample flow and disconnect the sample pipe. With the head in the down position the desiccant will dry the sensor, ready for the next test.

NOTE - It is important that the head assembly is either fully up, or fully down to keep the desiccant isolated from ambient air, so avoiding wetting it. When the SADPminiEx is not in use it should be stored with the head in the down position.

7 Sampling Information

Refer to the sample system schematic in section 4.2.

The SADPminiEx sensor will respond to the water vapour pressure of a gas in contact with it. It is important to ensure that the gas passing through the sensor head is the same as the gas being sampled.

7.1 Sample Pipe

The SADPminiEx is supplied with 2 connections: a “fir tree” on one side and a Swagelok® compression fitting for 1/4 in, 1/8 in, or 6mm OD pipe (as specified on your order) on the other. Either can be used as the inlet connection (6).

PTFE and stainless steel are recommended materials for sample pipes. Some specialist flexible tubing may be suitable as sample pipe, but common flexible tubing, such as pvc, nylon, polythene or rubber, should not be used, as they are permeable, and water vapour from the atmosphere will diffuse through them into the sample gas.

A 2m PTFE sample pipe is supplied for use with the “fir tree” connection. The first time this is used it is advisable to warm the end that will go over the “fir tree” for a few seconds with a heat source to soften it slightly, which helps to get a gas tight seal.

7.2 Sample conditioning

The main principle when considering the presentation of the gas sample to a portable dewpoint meter is to keep the sample system as simple as possible and of minimum swept volume, so that it has the least possible influence on the gas sample.

7.3 Pressure and flow control

In most cases the gas to be sampled will be at a positive pressure, which will need to be reduced to atmospheric pressure. At low pressures, up to around 10 barg, this can be done by including a simple needle valve (5) to control the flow and thereby, the pressure dropping across it. Ideally this would be the isolation valve (1) on the sample point, thus keeping the number of joints and glands, which are points of potential moisture ingress, to a minimum.

At higher pressures it is advisable to reduce the pressure across a pressure regulator (4). Any regulator used should be stainless steel and of a low swept volume. Typical laboratory or welding type regulators are not suitable because they have elastomeric diaphragms, which are permeable to water vapour, and the high swept volume will be slow to purge.

7.4 Particulate contamination

If the sample gas is likely to contain particulate material this should be kept away from the sensor by including a small in-line particle filter (3) in the sample system.

If the surface of the sensor becomes partly coated with particles it will not affect the calibration of the sensor, but will restrict the movement of water molecules across the surface, so increasing the time it takes for the sensor to come to equilibrium with the water vapour concentration around it. If the solid material is hygroscopic, such as desiccant dust, whenever there is a change in the moisture concentration in the sample this material must come to equilibrium with the moisture content before the sensor can respond to the change, which will cause delays in obtaining accurate results.

7.5 Liquid contamination

If the sample gas may contain liquid contamination, such as oil mist, this should be kept away from the sensor by including a coalescing filter or an appropriate membrane filter (3) in the sample system.

If the surface of the sensor becomes partly coated with liquid, again it will not affect the calibration of the sensor. It will restrict the movement of water molecules across the surface, so increasing the time it takes for the sensor to come to equilibrium with the water vapour concentration around it. If the liquid is hygroscopic, such as glycol, the buffering effect described for desiccant dust may be so great that the sensor becomes too slow to use.

8 SADPminiEx Initial Configuration

Each SADPminiEx is set up prior to despatch to the end users specification. The following values will be preset: -

- The specified sensor type is pre-selected.
- The calibration data will be set to values that are applicable to the specified installed sensor.
- The AutoCal value is set to match the installed sensor.
- The clock will be set to the correct date and time GMT.
- Moisture units set to °C Dewpoint.
- Pressure units set to barg, pressure value set to 0.
- Security codes are set to 1000.
- No Single point calibrations.

9 The Normal Display screen

When the SADPminiEx is ON, it displays the moisture level of the gas that the sensor is exposed too. When the head is lowered, the sensor is no longer exposed to the gas and is dried down by the desiccant in the head.

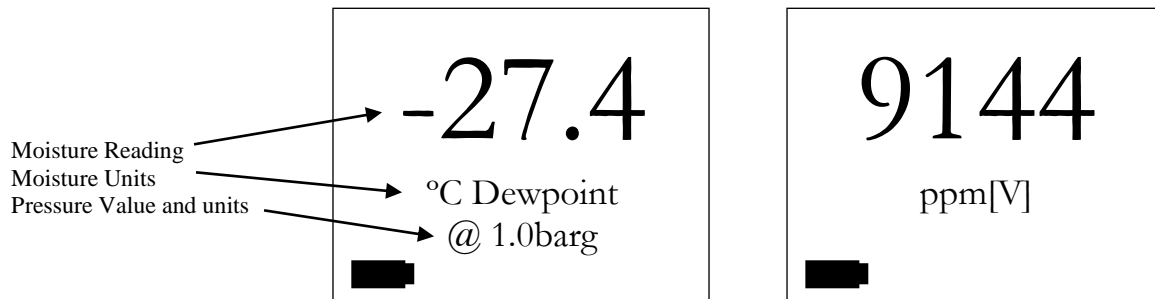

Examples of the Main Display Screen

The Display always shows the current moisture level that the internal sensor is exposed too. The current engineering units are clearly indicated on the display as well as any pressure compensation performed.

10 SADPminiEx operating principles

Two distinct and separate menus control the SADPminiEx. These menus are described in separate sections below:

10.1 Navigating through Menus

The SADPminiEx is predominantly menu driven. To navigate around the menus use the '▲' and '▼' keys to move the cursor bar (negative image) through the options available within the menu and use the '↵' key to select the option required. The '↶↷' key has no function within menu screens.

10.2 Entering Numerical Data

The basic principle used to enter numerical values is described here.

The display will indicate a number in a format appropriate to the required input, the first character of which will be displayed as a negative image to indicate it is active. Use the '▲' and '▼' keys to select the required number between 0 and 9 then press the '↵' key to select and proceed to the next character. Continue this process until all characters are entered. Pressing the '↵' key, at any point, enters the numerical value currently displayed.

Notes

- Where control values are entered (such as 4-20mA) the currently set value is displayed when first entering the screen. This allows the user to simply press the ‘↵’ key and leave the screen without altering any information. Useful when entering a function by accident.
- The decimal point (dp) will always appear in the correct location.
- On some screens when using °C or °F the first digit is the negative sign selector. This is either ON or OFF.
- Pressing the ‘↶↷’ key when the last character is active will make the first character active.

10.3 Entering Alphanumerical Data

(Full Logging SADPminiEx only)

Some functions such as the “Create TAG” allow the user to enter a combination of letters and numbers. The principle for entering data is the same as that for entering numerical data (10.2 above) except that the ‘▲’ and ‘▼’ keys scroll through the 26 letters of the alphabet as well as the 10 numerical characters.

Note – There is a dual speed function when entering alphanumerical data. When either the ‘▲’ or ‘▼’ key is pressed and held, the speed of scroll will increase.

10.4 Security Protection Screens

Several of the SADPminiEx functions can be protected with security codes. These are the main ‘Setup Menu’, the ‘AutoCal’ function, and the ‘SPC’ (Single Point Calibration) function. Each of these functions can be protected with an independently activated user defined 4-digit security code. Once activated, a screen requesting the correct code will be displayed when the associated function is selected. Failure to enter the correct code will prevent access to the function. **Default setting 1000**

11 Operating the SADPminiEx

11.1 The Setup Menu

(See Appendix C - SADPminiEx Setup Menu Map)

The setup menu is activated by pressing the ‘↶↷’ and ‘↵’ keys simultaneously. From this menu, the user has the choice of several options detailed below:

11.1.1 Select Units

Description – This sub-menu has eight options allowing the user to select any one of seven Moisture Engineering Units and to exit the menu.

Note: - 1) Once an engineering unit is selected, the SADPminiEx will only display and accept inputs in that chosen unit. This means that 4-20mA settings (where fitted), offsets and SPCs are all performed in the chosen units.
2) The 4-20mA range settings are reset to full span whenever the moisture units are altered.

Operation – In the ‘Setup Menu’ move the cursor bar to highlight the ‘Select Units’ option and press the ‘↵’ key. The ‘Primary Units’ sub-menu is displayed. Run through the options until the required engineering unit is highlighted; confirm the selection by pressing the ‘↵’ key. The SADPminiEx automatically reverts to the ‘Exit’ option in the ‘Setup Menu’.

Note: The PPB Moisture Engineering Units has an upper display limit of 10000 PPB, Change units to PPM above this moisture level.

11.1.2 Pressure Calc

Description – This sub-menu has five options allowing the user to select any one of four Pressure Engineering Units and to exit the menu. This function then allows the SADPminiEx to display Dewpoint °C and °F at @ pressure. When this function is selected, the main display screen will display the pressure at which the Dewpoint reading is calculated.

Operation – In the ‘Setup Menu’ select the ‘Pressure Calc’ option. In the ‘Pressure Units’ sub-menu run through the options until the required engineering unit is highlighted; confirm the selection by pressing the ‘↵’ key. The SADPminiEx then requires that a numerical pressure value be entered in the selected units. The display format relates to the pressure units chosen. Once a pressure value is entered, the SADPminiEx automatically reverts to the ‘Exit’ option in the ‘Setup Menu’.

Note: See ‘SADPminiEx Specification’ for detailed information on Pressure Engineering Units.

Warning: This function is purely an internal calculation and **DOES NOT** allow an elevated pressure to be applied to the measuring head.

11.1.3 4-20mA Output (4-20mA and Full Logging versions only)

FOR USE IN SAFE AREA ONLY

Description – The 4-20 option allows the user to set the range over which the 4-20mA output will span. The default setting is for the output range to cover the full operating range of the sensor type fitted in the SADPminiEx e.g. for a ‘B’ type sensor 4mA equals –80°C and 20mA equals 20°C. However, it is possible to set a more focused range, such as 4mA equals –60°C and 20mA equals –20°C.

Operation – In the ‘Setup Menu’ select the ‘4-20mA Output’ option. The SADPminiEx requires that a value be entered for the 4mA lower limit. The current value is displayed, in the active moisture-engineering units. Once the new value is entered, the SADPminiEx requires that another value be entered for the 20mA upper limit. Once that new value is entered, the SADPminiEx automatically reverts to the ‘Exit’ option in the ‘Setup Menu’.

- Note** –
- 1) The only way to leave this menu without altering any values is to press the ‘↵’ key twice, accepting the current values for both the upper and lower settings.
 - 2) The 4-20mA range settings are reset to full span whenever the moisture units are altered.
 - 3) The 4-20mA output should not be operated while the instrument is charging.

11.1.4 AutoCal

Description – AutoCal allows the user of the SADPminiEx to ensure accuracy between laboratory calibrations by checking the span of the instrument and correcting for any deviation.

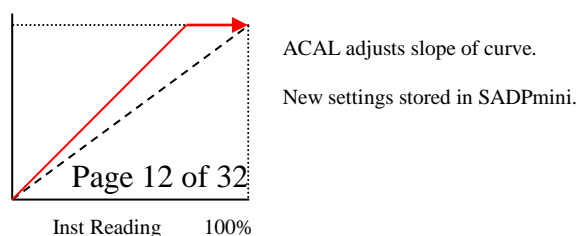

For Sensors with upper range limit of -20 or 0°C dewpoint.

The AutoCal facility uses the fact that each sensor is designed and manufactured to give no further increase in response when it reaches its maximum moisture level. For example an SADPminiEx with a full-scale value of -20°C dewpoint will read -20°C dewpoint when exposed to a gas with this moisture concentration, and will continue to read -20°C dewpoint as the moisture concentration rises above -20°C dewpoint. The SADPminiEx can, therefore, be adjusted to read -20°C dewpoint on any gas with a moisture concentration wetter than -20°C dewpoint, ambient air for instance, thus setting the span to match the original calibration.

AutoCal should be operated periodically, every 2 to 3 months, say, or can be used to verify operation of the SADPminiEx if confirmation of an unexpected result is required.

Operation – of SADPminiEx units with full scale values of -20°C or 0°C dewpoint

1. Select AutoCal from the Set-up Menu
2. Follow the on-screen instructions, i.e.:
 - i) Extend the desiccant head and press the ‘↵’ key.
 - ii) The SADPminiEx will display a moving bar until it assesses that the sensor has stabilised. (Up to 10 mins.)
 - iii) The SADPminiEx will now display the full-scale value of the unit, either -20°C or 0°C. If the unit is being checked against a known moisture level such as from a moisture generator the scroll and ▲ and ▼ keys can be used to enter the known moisture level, otherwise leave it set at the full-scale value and press the ‘↵’ key.
 - iv) The SADPminiEx will display a moving bar whilst the calibration data is modified. (Up to 5 mins.)
 - v) Close the desiccant head when instructed to do so and press the ‘↵’ key.
 - vi) The SADPminiEx will return to the Set-up Menu with the “EXIT” option highlighted. Pressing ‘↵’ key again will return the instrument to operational mode.

Note - Avoid carrying out the AutoCal procedure on a SADPminiEx with a full scale value of 0°C dewpoint on days when the ambient dewpoint may be below this value.

For Sensors with upper range limit of +20°C dewpoint.

Operation – of SADPminiEx units with full scale values of +20°C dewpoint

- i) The ambient dewpoint should be determined using reference standard, such as a chilled mirror hygrometer or a psychrometer, unless the instrument is being checked against a known calibration standard, from a moisture generator.
- ii) Extend the desiccant head and press the ‘↵’ key.
- iii) The SADPminiEx will display a moving bar until it assesses that the sensor has stabilised. (Up to 10 mins.)

- vii) The SADPminiEx will now display the full-scale value, 20°C dewpoint. Whether the instrument is being checked against the measured ambient level or against a known calibration standard, from a moisture generator, for example, the scroll and ‘▲’ and ‘▼’ keys are used to set the value accordingly. (If a different value has been entered in this way previously the SADPminiEx will display that value, rather than 20°C dewpoint.) Press the ‘↵’ key when done.
- iv) The SADPminiEx will display a moving bar whilst the calibration data is modified. (Up to 5 mins.)
- viii) Close the desiccant head when instructed to do so and press the ‘↵’ key.
- ix) The SADPminiEx will return to the Set-up Menu with “EXIT” highlighted. Pressing ‘↵’ key again will return the instrument to operational mode.

- Note** –
- 1) Pressing the scroll key during the AutoCal **ABORTS** the process. The AutoCal value present at the start of the aborted AutoCal process is reinserted. The instrument is **OUT OF CALIBRATED**.
 - 2) If the Instrument fails to AutoCal (excessive sensor degradation) a message to this effect will be displayed on the LCD screen until acknowledged by the user.
 - 3) In both cases the instrument will be **OUT OF CALIBRATION** until a successful AutoCal is performed. This will mean replacing the sensor in some cases.
 - 4) The entered AutoCal Value must not be pressure compensated (see 11.1.2).

11.1.5 SPC (Single point Calibration)

Description – The SPC facility allows users of the SADPminiEx to check the reading of the instrument against a “standard reference gas” or instrument, such as a chilled mirror unit, at a particular value that may be considered to be critical, and make any adjustment necessary to give agreement with that “standard reference.”

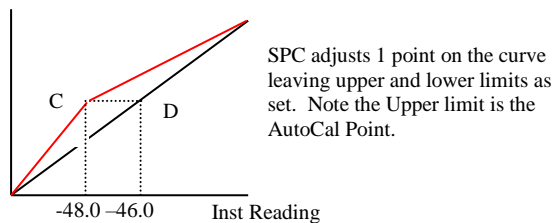

Rather than making the adjustment to the span of the instrument, as with AutoCal, the SPC adjustment is made by introducing a two-part straight-line response curve with a break point at the set point, or “standard reference.”

SPC Procedure

1. An AutoCal **must be** carried out before performing an SPC.
2. Measure the value of the reference gas with the SADPminiEx in the normal way and note the indicated value and the stated value of the “standard reference.” [For example, the SADPminiEx reads -70°C dewpoint, and the “standard reference gas” is certified by the gas supplier as being -69°C dewpoint]. The instrument can now be removed from the gas sample, to conserve the reference gas.

3. Select 'SPC' from the Set-up Menu and Press the '↵' key.
 - i.) On the warning screen press the '↵' key to continue (pressing Scroll key will abort the procedure and go back to the Set-up Menu).
 - ii.) Enter the password (if required) and press the '↵' key.
 - iii.) Highlight the 'ENTER NEW SPC' option to add a SPC to the SADPminiEx and Press the '↵' key.
 - iv.) The display asks for the "SPC POINT," enter the value measured for the reference gas (i.e. -70°C in the above example) using the Scroll and '▲' and '▼' keys and press the '↵' key.
 - v.) The display asks for the "SPC VALUE," enter the stated value for the reference gas (i.e. the value that you want the SADPminiEx to read at this point, -69°C in the above example) using the Scroll and '▲' and '▼' keys and press the '↵' key.
 - vi.) The SADPminiEx will revert to the Set-up Menu with EXIT highlighted, pressing the '↵' key will return the instrument to the operating mode and all readings taken will be modified in line with the offset introduced in the above procedure.

Note- The integrity of the calibration will now be dependent on the integrity of the reference standard against which the adjustment has been made. To restore the factory calibration, and thus the traceability stated in the Certificate of Calibration, the SPC adjustment must be removed.

4. To remove a SPC from the SADPminiEx follow the above procedure to step iii.) Then select the 'REMOVE SPC' option and Press the '↵' key. The SADPminiEx will revert to the Set-up Menu with the SPC removed.

11.1.6 Security

Description – This sub-menu allows the user to alter any of the three user defined 4-digit security codes see 8.4 above.

Operation – In the 'Setup Menu' select the 'Security' option. In the 'Select Code' sub-menu run through the options until the required code is highlighted; confirm the selection by pressing the '↵' key. The user is then requested to enter the current (old) security code. If the correct code is entered, the user is then requested to enter the new security code. Failure to enter the correct code will drop the user back into the 'Setup Menu'. The default value for all security codes is '1000'

Note: '0000' is a special code that deactivates the security code for the selected functions. Where '0000' is used, the security code screen will be bypassed.

11.1.7 Time and Date

Description – This function allows the user to view the set 'Time' and 'Date' without having to enter the Set Clock function.

Operation – In the 'Setup Menu' select the 'Time and Date' option.

11.1.8 Set Clock

Description – The Clock option allows the user set the SADPminiEx internal Real Time Clock.

Operation – In the ‘Setup Menu’ select the ‘Set Clock’ option. The user is prompted to enter the Date in the DD/MM/YY format followed by the time in the HH:MM:SS in 24-hour format.

Note: Although the second’s digits are displayed they are not selectable

11.1.9 Information

Description – The Information menu displays all of the SADPminiEx current settings.

Operation – In the ‘Setup Menu’ select the ‘Information’ option. The ‘Information’ sub-menu allows the user to run through the displayed data using the ‘▲’ and ‘▼’ keys. Exit the menu by pressing the ‘↵’ key at any location or by scrolling to the Exit option.

Note: There are no selectable operations from this menu; it is purely for information purposes.

Displayed Information		Description
VerNo	5.11	Software Version Number
Serial	500101	Unit Serial Number
Read L	-80.0	Lower Limit
Read H	20.0	Higher Limit
ACAL	10.0	AutoCal Value
SPC Pt	20.0	Single Point Calibration Action Point.
SPC Va	20.0	Single Point Calibration Offset Value.
Units	°C	Currently Set Engineering Units
P Unit	barg	Currently Set Pressure Units
Press	00.0	Currently Set Pressure Value in Current Units
Sensor	B	Type of Sensor fitted to SADPminiEx
4mA	-80.0	Low mA output in Currently Set Engineering Units.
20mA	20.0	High mA output in Currently Set Engineering Units.
Epot	384	Position of the electronic AutoCal potentiometer
Exit		Exit option

11.1.10 Temperature

Description – This function allows the user to see the current temperature within the SADPminiEx head in both °C and °F.

Operation – In the ‘Setup Menu’ select the ‘Temperature’ option.

11.1.11 Exit

Description – The Exit option allows the user to return to the normal display.

Operation – In the ‘Setup Menu’ select the ‘Exit’ option.

11.2 The Logging Menu (Full logging versions only)

NOTE: This internal function can be performed in hazardous areas.

Transferring data to a PC cannot be performed in hazardous areas - See section 16, from page 24.

See also Appendix C for SADPminiEx Logging Menu Map.

The Logging menu is activated by pressing the ‘▲’ and ‘▼’ keys simultaneously. From this menu, the user has the choice of several options detailed below:

11.2.1 Internal Logging

Description – This function allows the user to store data to the unit’s internal memory, from where it can be exported or reviewed. There are 20 available TAG references, each of which can store up to 20 data blocks (a file where data points are stored). This means that a maximum of 400 separate data blocks can be stored. The SADPminiEx has a capacity of 16000+ individual data points.

Note: If the number of data points in a single block exceeds 12800 only the first 12800 will be downloaded from the SADPmini to a PC. It is therefore recommended that a sample rate be chosen that over the logging period will result in less than 12800 readings being taken

Operation – In the ‘Logging Menu’ select the ‘Internal LOG’ option. The user is then presented with the ‘Select Log TAG’ menu showing available TAG references for data storage. (See Create, Edit & Delete TAG options for more information). Highlight the required TAG reference and press the ‘↵’ key to select.

Note: TAG1 is the default TAG reference and cannot be deleted. If no other, TAG references have been created, the ‘Select Log TAG’ menu does not appear and the unit will automatically select to log data to TAG1. Also ‘EMPTY’ means the TAG reference has not been defined using ‘Create TAG’ and as such is not useable.

Each TAG can store up to 20 separate data files called data blocks.

Once the required TAG reference is selected, the user is required to enter an interval between readings in minutes. The default setting is 0.1 minutes or 6 seconds. As the interval is changed, the SADPminiEx displays the length of time that the unit could successfully log data for in terms of memory space.

Note: this forecast is not an indication of battery life; long tests should be performed on external power.

Pressing the ‘↵’ key starts the logging process and brings up the ‘Internal LOG’ display screen, which indicates the current moisture value, the number of data points read and the TAG reference where the data is stored. Pressing the ‘▲’ key at any point will stop logging.

Note: A minimum of 4 stored data readings is required for the data to be reviewed by the SADPminiEx.

11.2.2 Review Data

Description – This function allows the user to review data stored in the unit’s internal memory in both tabular and graphical format.

Operation – In the ‘Logging Menu’ select the ‘Review DATA’ option. The user is then presented with the ‘Review TAGs’ menu showing all current TAG references. Highlight the required TAG reference and press the ‘↵’ key to move to the block selection screen.

The selection screen shows the TAG reference, block number plus the date & time when data was stored. The SADPminiEx by default displays the most current data block first and subsequently runs through the remaining blocks in chronological order.

Pressing the ‘↶↷’ key displays the next block of information.

Pressing the ‘↵’ key displays the select block and the associated data in graphical format.

Note: ‘EMPTY’ means the TAG reference has not been defined using ‘Create TAG’.

The graphical displayed shows the stored data vs number of readings

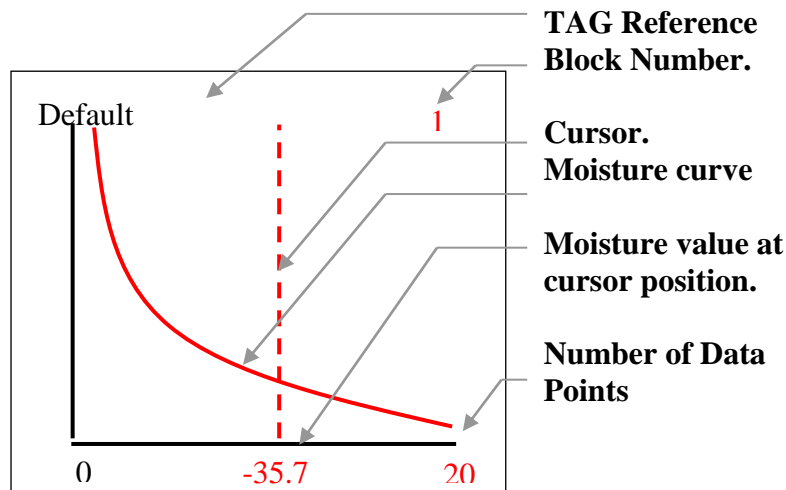

Pressing the ‘▲’ and ‘▼’ keys moves the cursor along the X-axis of the graph. The Moisture value printed in the middle of the X-axis changes to indicate the value at the point where the cursor crosses the moisture curve.

Pressing the ‘↶↷’ key changes the format of the displayed from tabular to graphical and visa versa.

The tabular display shows the TAG reference, block number, moisture units and 6 moisture readings. The ‘▲’ and ‘▼’ keys allow the user to scroll in both directions through the stored data values.

Pressing the ‘↵’ key from either display format returns the user to the ‘Logging Menu’.

11.2.3 PC Comms

FOR USE IN SAFE AREA ONLY

Description – This function is selected by the user to download store data or to Real-time log data, to a connected PC.

Operation – In the ‘Logging Menu’ select the ‘PC COMMS’ option. Ensure the SADPminiEx is connected to the PC using the cable supplied. Start the PC software (See SADPminiEx Logger software user guide) and press the ‘↵’ key twice.

Note: Pressing the '▲' key terminates communications with the PC and returns the display to the 'Logging Menu'

11.2.4 Delete Data

Description – This function allows the user to completely delete all data stored on the SADPminiEx. Once deleted the data is not recoverable.

Operation – In the 'Logging Menu' select the 'Delete DATA' option. The unit displays a warning and allows the user to return to the 'Logging Menu' without deleting the data by pressing the '↵' key. Pressing the '↶↷' key deletes all the data irretrievably.

11.2.5 Create TAG

Description – This function allows the user to define 19 bespoke references of up to 11 characters in length. TAG1 is predefined and cannot be created.

Operation – In the 'Logging Menu' select the 'Create TAG' option. The 'Enter TAGS' screen then allows the user to create a TAG reference by pressing the '↶↷' key or return to the 'Logging Menu' by pressing the '↵' key.

The 'Create TAG' screen enables the user to produce an 11-character reference using an alphanumeric editor. The '▲' and '▼' keys allow the user to scroll through the full alphanumeric character set in both directions. The '↶↷' key moves on to the next character.

Note: When the 11th character is highlighted the '↶↷' key moves the cursor to the 1st character..

Pressing the '↵' key saves the TAG reference and returns the user to the 'Enter TAGS' screen so another TAG can be created.

11.2.6 Edit TAG

Description – This function allows the user to edit any of the 20 TAG references. TAG1 is predefined as Default TAG but can be edited.

Operation – In the 'Logging Menu' select the 'Edit TAG' option. The user is then presented with the 'Edit TAG' menu showing all current TAG references. Highlight the required TAG reference and press the '↵' key to move to the 'Edit TAG' screen. The bottom item on the menu is an 'EXIT' function that returns the user to the 'Logging Menu'.

The 'Edit TAG' screen operates in exactly the same way as the 'Create TAG' screen.

11.2.7 Delete TAG

Description – This function allows the user to delete any of the 19 TAG references produced using the 'Create TAG' function.

Operation – In the ‘Logging Menu’ select the ‘Delete TAG’ option. The user is then presented with the ‘Delete TAG’ menu showing all current TAG references. Highlight the required TAG reference and press the ‘↓’ key to move to the ‘Delete TAG’ screen. The bottom item on the menu is an ‘EXIT’ function that returns the user to the ‘Logging Menu’. The ‘Delete TAG’ screen allows the user to delete the TAG reference by pressing the ‘↓’ key or return to the ‘Logging Menu’ without deleting the TAG reference by pressing the ‘↶↷’ key.

Note: When a TAG reference is deleted all the associated data blocks are also lost.

When a TAG reference is deleted, its slot is filled with the word EMPTY. TAG1 cannot be removed, when deleted it is renamed back to the predefined reference of ‘Default TAG’.

11.2.8 Printer LOG

SAFE AREA ONLY

Description – This function allows the user to real-time log the moisture value seen by the SADPminiEx to any ASCII thermal printer via the RS485 ‘D’ type connector communications port. The SADPminiEx outputs ASCII strings unsolicited without the need for handshaking at the interval selected.

Operation – In the ‘Logging Menu’ select the ‘Printer LOG’ option.

The user is required to enter a value for the interval between readings in minutes. The default setting is 0.1 minutes or 6 seconds. Pressing the ‘↓’ key starts, the logging process and brings up the ‘External LOG’ display screen, which indicates the current moisture value.

Pressing the ‘▲’ key at any point will stop logging.

Note: By default the SADPminiEx will output a moisture value in the current units every 6 seconds.

11.2.9 Unit Address

Description – It is possible to communicate with up to 32 SADPminiEx units via the RS485. However, for this to operate correctly each unit must have a different address. The default address setting for the SADPminiEx is 1.

Operation – In the ‘Logging Menu’ select the ‘Unit Address’ option. The user is then required to enter the required address using the standard numerical editor format. Pressing the ‘↓’ key confirms the new address.

11.2.10 Free Space

Description – This routine allows the user to see how much space is available in the SADPminiEx memory, in terms of logged readings.

Operation – In the ‘Logging Menu’ select the ‘Space Free’ option. The screen automatically reverts to the ‘Logging Menu’ after 3 seconds.

11.2.11 Exit

Description – The Exit option allows the user to return to the normal display.

Operation – In the ‘Logging Menu’ select the ‘Exit’ option.

12 Pressure Correction

When a line pressure is entered (see 9.1.2) and °C or °F have been selected the displayed moisture value is pressure corrected. The fact that pressure correction is active is indicated by the phrase “@ 10 barg” (or some variation) been displayed.

Pressure corrected values are also used in the External Log and Internal Log screens when °C or °F are the selected units.





Warning: This function is purely an internal calculation and **DOES NOT** allow an elevated pressure to be applied to the measuring head.

13 Battery Current Status

Only use the Charger supplied with SADPminiEx

The battery Icon in the bottom left-hand corner of the display indicates the status of the battery.

The internal battery is a 3.7V, 750mAh Lithium-Polymer encapsulated rechargeable cell. The Icon indicates the battery voltage as follows: -

OFF	Less than 3.3V dc
	3.3 to 3.38V dc
	3.38 to 3.46V dc
	3.46 to 3.54V dc
	3.54 to 3.62V dc
	Greater than 3.62V dc

The Icon fills from the left when the external power supply is connected. This indicates that the battery is receiving a charging current and should be fully charged within 14 hours.

Note: It is recommended that the unit be charged overnight when first received to ensure the battery is fully charged.

Note: The 4-20mA output should not be operated while the instrument is charging.

14 SADPminiEx 4-20mA

SAFE AREA ONLY - Connecting unapproved equipment to the terminals of the instrument could cause the instrument to become unsafe for use in the hazardous area and will invalidate the intrinsically safe certification.

Note: The 4-20mA output should not be operated while the instrument is charging.

The 4-20mA signal gained from the SADPminiEx is loop powered only. The connections are:

4-20mA output CON066 connector Pin 5
 Loop Power input CON066 connector Pin 9



14.1 SADPminiEx 4-20mA Circuit

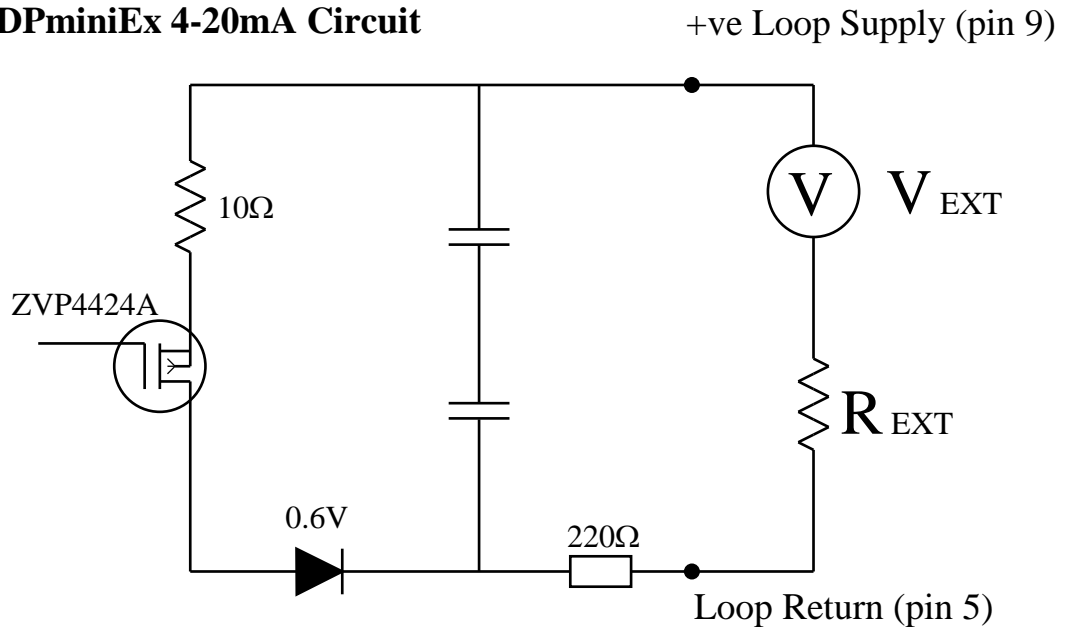

14.2 Calculating Maximum Output Load (R_{EXT})

$$R_{EXT} = \frac{(V_{EXT} - 0.6) - 240}{0.02}$$

Examples $V_{EXT} = 12V : R_{EXT} = 350\Omega$
 $V_{EXT} = 15V : R_{EXT} = 480\Omega$
 $V_{EXT} = 24V : R_{EXT} = 930\Omega$
 $V_{EXT} = 28V : R_{EXT} = 1130\Omega$

15 RS485 Communications

SAFE AREA ONLY - Connecting unapproved equipment to the terminals of the instrument could cause the instrument to become unsafe for use in the hazardous area and will invalidate the intrinsically safe certification.

The RS485 Half Duplex communications signal is driven by a MAX3471 interface chip. The SADPminiEx connections are: -

RS485 (B)	Connector Pin 7
RS485 (A)	Connector Pin 1
GND	Connector Pin 8

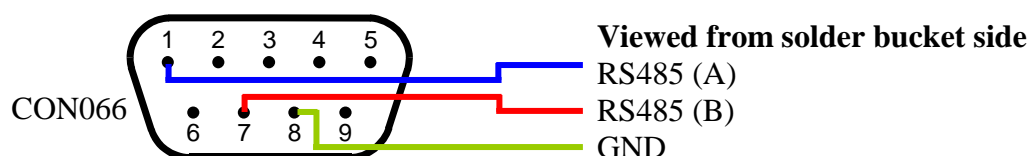

16 SADPminiEx Logging Software Cables and Interfaces

FOR USE IN SAFE AREA ONLY

There are 2 types of interface that can be used with the SADPminiEx and SADPminiEx Logging software.

16.1 RS232 to RS485 Cables & Interface

FOR USE IN SAFE AREA ONLY - Connecting unapproved equipment to the terminals of the instrument could cause the instrument to become unsafe for use in the hazardous area and will invalidate the intrinsically safe certification.

Recommended for Windows XP®, 7 and 8.

The Interface unit INT007 has two 9-way 'D' type connectors. The connector marked with a 'B' connects to a PC or Laptop serial Port using a 2.0m serial cable (Part No: CAB029). The connector marked with a 'S' connects to the SADPminiEx using a 1m special cable (Part No: CAB032).

The INT007 has a facility to connect a +12v DC power supply (2.5mm plug with positive tip). This supply is only required when the PC or Laptop connected to the SADPminiEx is not able to supply 100mA. Generally, PC's do not require this power supply. Laptops may require the supply for distances above 15m RS232 side and 275m RS485 side.

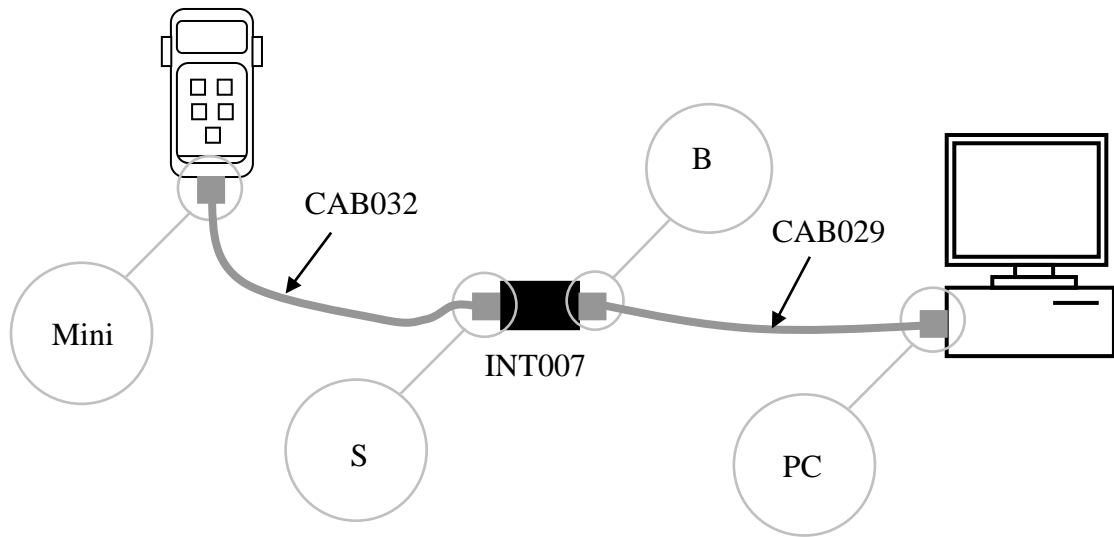

16.2 USB to RS485 Cables & Interface

FOR USE IN SAFE AREA ONLY - Connecting unapproved equipment to the terminals of the instrument could cause the instrument to become unsafe for use in the hazardous area and will invalidate the intrinsically safe certification.

Recommended for Windows XP®, 7, 8 and 10.

The Interface unit INT008 has a 9-way 'D' type connector and a USB connector. The USB connects to a PC or Laptop USB Port using a 1.8m USB cable (Part No: CAB031). The 'D' type connects to the SADPminiEx using a 1m special cable (Part No: CAB033).

Note: The drivers for the USB Interface are supplied on the included CD. When Windows asks for the drivers simply insert the CD and navigate to it.

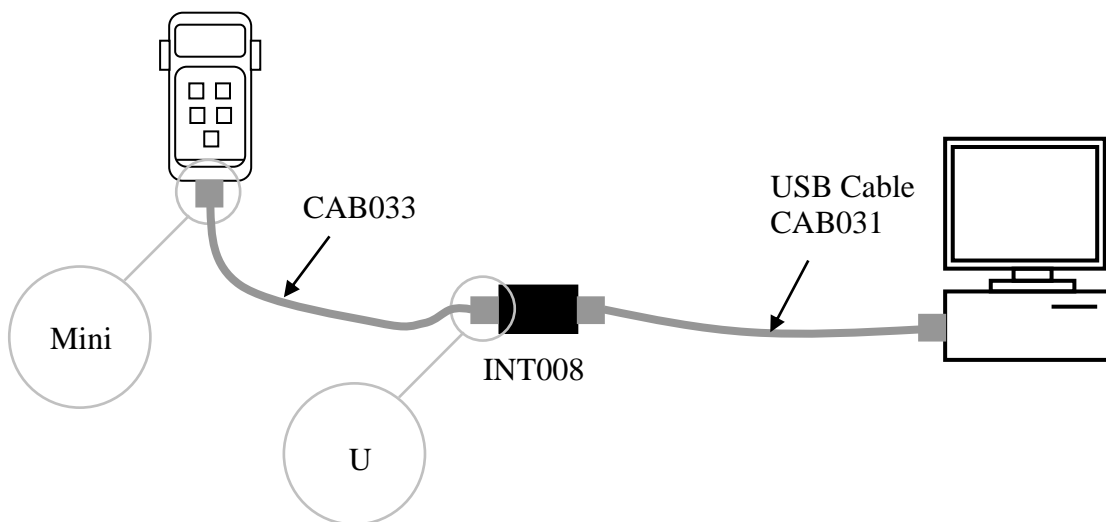

17 Technical Details of the RS485\4-20mA Connector (CON066)

SAFE AREA ONLY - Connecting unapproved equipment to the terminals of the instrument could cause the instrument to become unsafe for use in the hazardous area and will invalidate the intrinsically safe certification.

The CON066 connector can be wired as a 4-20mA connector or as a dedicated RS485 connector. The CON066 is a kit of parts consisting of 2 half shells (1), 2 locating screws (2), 2 fixing screws (3), a 'D' type connector and 4 assorted size clamps (4).

To assemble the CON066 follow the sequence below using the diagram for reference:-

1. Solder wires to the correct bucket pins of the 'D' connector – see appropriate section for pinouts, 16.1 for "4-20mA" and 16.2 for "RS485".
2. Select the appropriate clamps (4) for the cable being used.
3. Insert 1 half of the clamp (4) in the bottom half shell (1).
4. Place the 'D' connector in the bottom half shell (1), ensuring the bottom edge of the connector is situated in the slot.
5. Pass the cable over the half clamp (4). Connect the top half of the clamp.
6. Insert the 2 locating screws (2) ensuring the screw threads protrude through the 'D' connector.
7. Offer up the top half shell.
8. Secure using the 2 fixing screws (3).

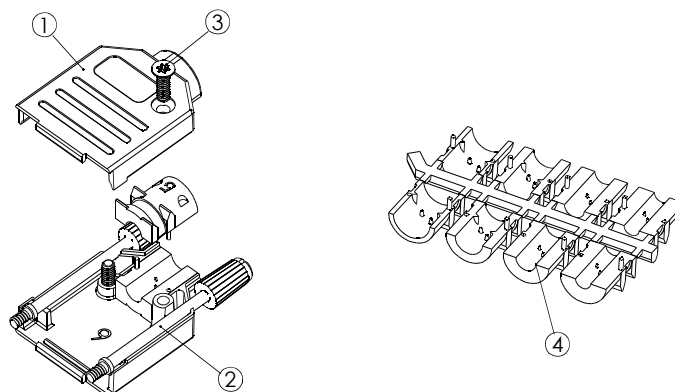
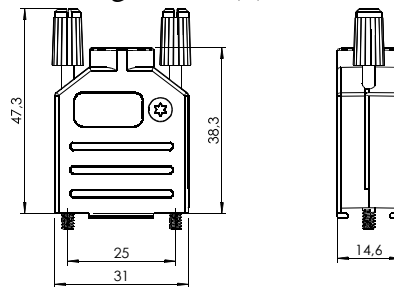

Note: This connector is not used in conjunction with the SADPmini logging software. See section 16.0 for cables used with the SADPmini logging software.

18 SADPmini Protocol

Contact your supplier for the “SADPmini Protocol Manual”.

19 Instructions for Replacing Desiccant in the SADPminiEx

FOR USE IN SAFE AREA ONLY

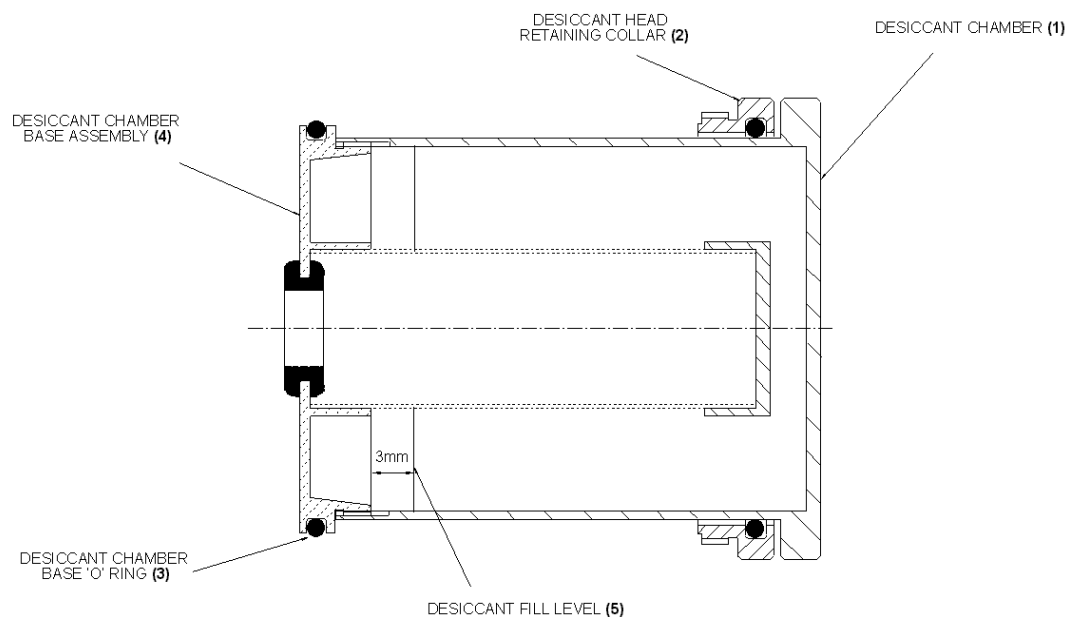

1. Fully extend the Desiccant head (1) of the SADPminiEx.
2. Unscrew the Retaining Collar (2), turning it counter clockwise (anti-clockwise), which will unfasten the desiccant filled head from the main body of the SADPminiEx.
3. Gently pull out the Desiccant Head from the main body of SADPminiEx.
4. Remove the Desiccant Head Base “O” Ring (3) and keep in safe place.
5. Holding the Desiccant Head with the Desiccant Base Assembly (4) on top, fully unscrew the Desiccant Head Base Assembly turning it counter clockwise (anti-clockwise). The Desiccant Head base may require slight loosening by placing in a soft jaw vice before this step is carried out. Do not fully unscrew with Head Base at the bottom, as this will spill desiccant on floor. **ONLY USE SOFT JAWS. DO NOT USE TOOLS OR VICE WITH HARD JAWS.**
6. Dispose of used desiccant and re-fill with new up to a level of 3mm (5) from the bottom of the screw thread.
7. Gently insert the Desiccant Head Base Assembly in the desiccant and tighten. **USE SOFT JAWS - DO NOT USE TOOLS OR VICE WITH HARD JAWS.**
8. Fit Desiccant Head Base “O” Ring (3)
9. Insert Desiccant Head in the main SADPminiEx body and tightly screw in the Retaining Collar.

20 Appendix C – SADPminiEx Setup Menu Map

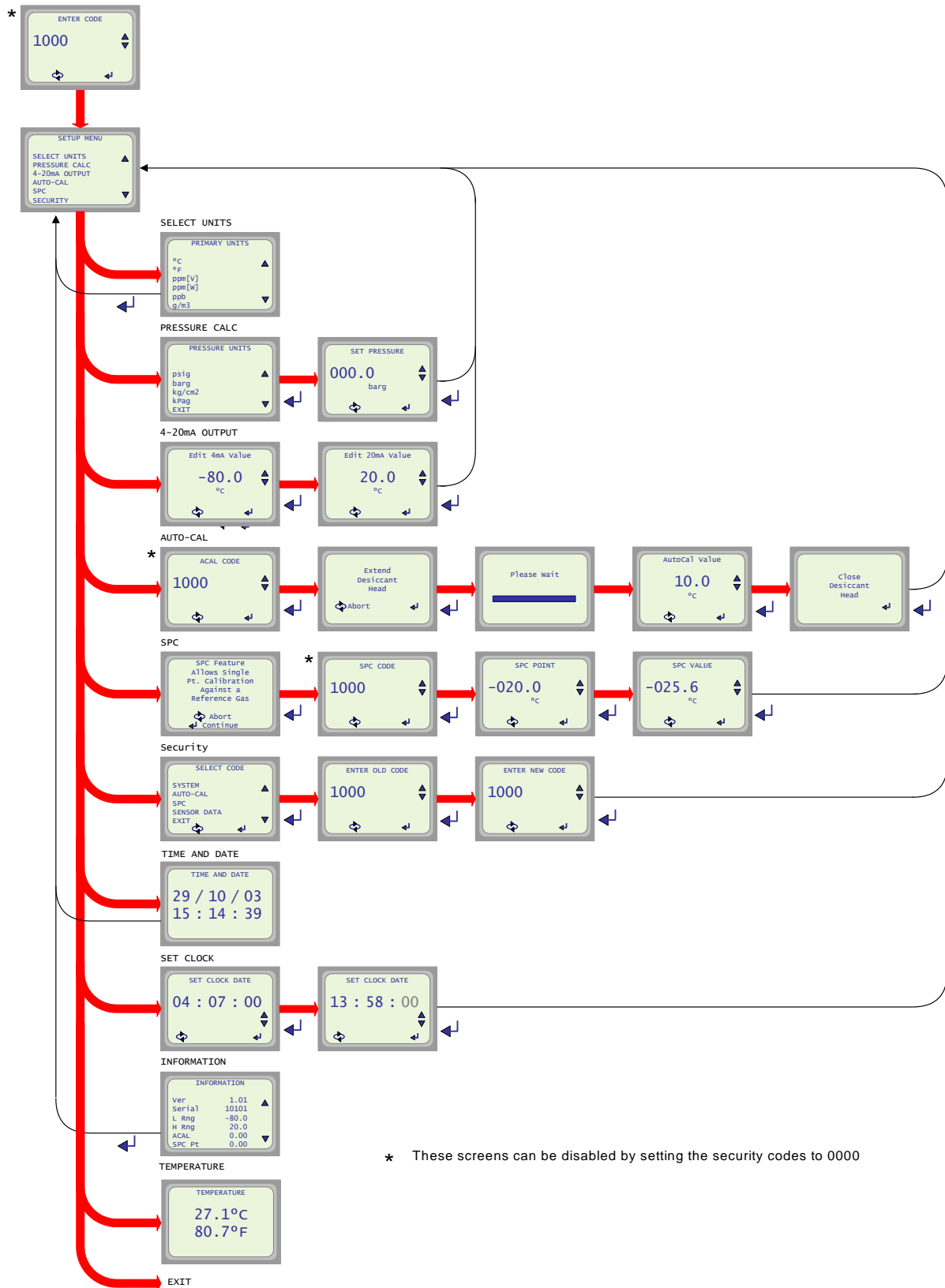

21 Appendix D – SADPminiEx Logging Menu Map

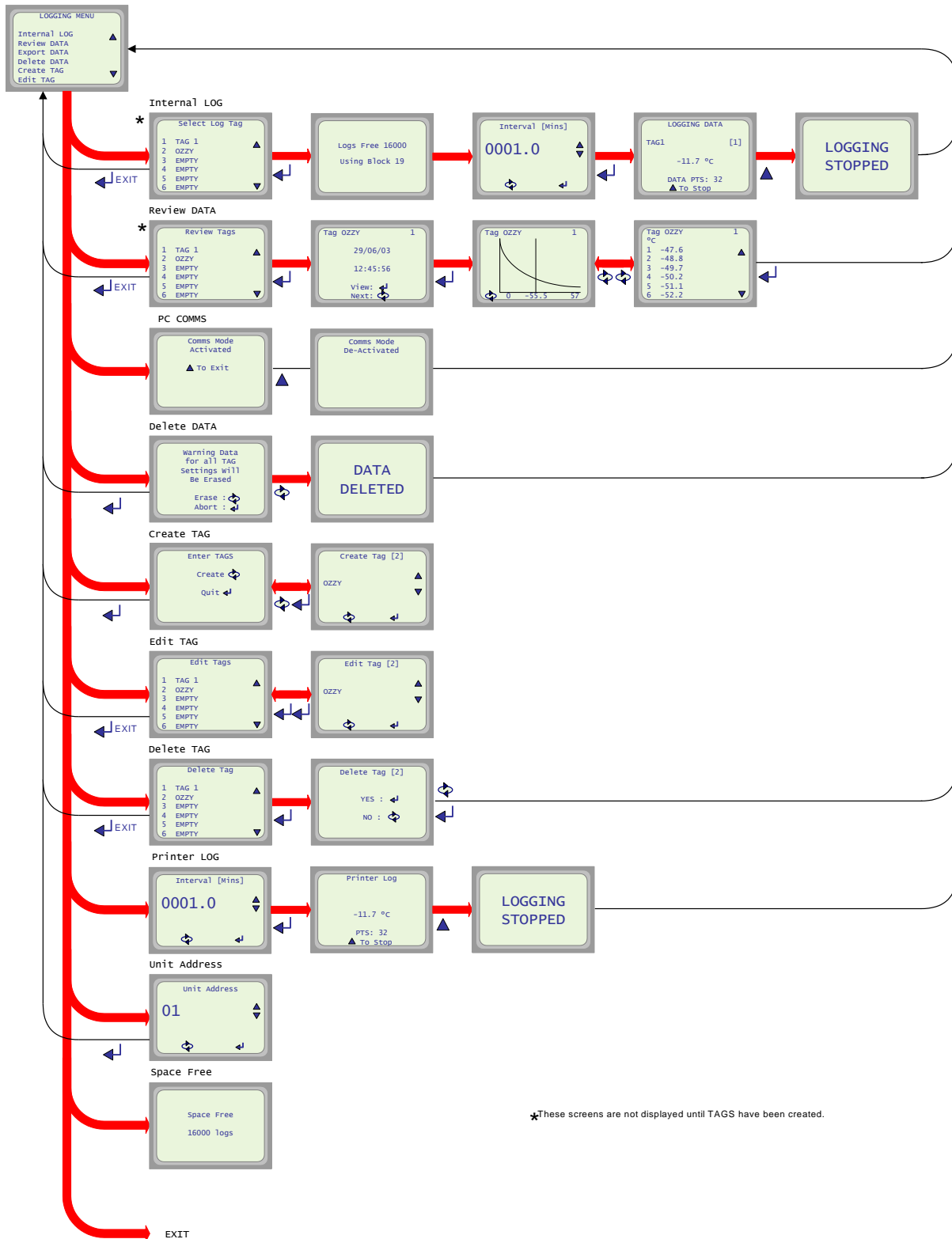

22 Appendix E – Trouble Shooting

Fault	Explanation	Required Action	Notes
Unit does not turn on. Screen remains blank. Back light off	Battery low level	Connect the battery charger unit for a minimum of 14 hours charging.	Connecting the external battery charger will not allow the unit to turn on, as the charger unit is not a PSU and the battery level will need to rise before the unit will turn ON.
“	Battery dead	Replace battery	Contact Alpha Moisture Systems with Instrument Serial Number.
Unit refuses to turn on. Screen remains blank although the backlight may be on.	µProcessor locked up	Press the reset switch under the port cover. Situated behind the pinhole.	It may be necessary to press the I/O key whilst pressing the reset switch.
Logging Menu Does not Work	Not a Logging version see Type Label	N/A	Upgrade unit to Logging version if required. Contact Alpha
“	No communication with PC	See Logging Software trouble shooting section.	
4-20mA output does not work	Not a 4.20mA version see Type Label	N/A	Upgrade unit to 4-20mA version if required. Contact Alpha
Unit does not read the Upper Limit when head open	Unit needs AutoCal	Perform AutoCal as per manual.	
AutoCal Failure	Sensor sensitivity too low	Repeat AutoCal	If AutoCal Fails contact supplier to replace sensor.
Unit always reads Lower Limit	Sensor cable broken	Repair Cable	
Unit will not dry down to Lower Limit	Sieve Wet	Perform service on unit using Service Kit.	Service kit available from supplier
“	‘O’ Ring Failure	Perform service on unit using Service Kit.	Service kit available from supplier
Battery has short life between charges	Battery reaching end of life	Replace battery	Order BAT007 from supplier
Unit does not respond to key presses.	µProcessor Locked Up	Press the reset switch under the port cover. Situated behind the pinhole.	
“	Keypad damaged	Check function of keypad electrically	Contact Supplier

If “Required Action” does not correct the fault then contact your supplier.

23 Appendix F – SADPminiEx Specification

Unit Details

Dewpoint Ranges:	-80°C DP to -20°C DP -80°C DP to 0°C DP -80°C DP to +20°C DP -110°C DP to -20°C DP -100°C DP to 0°C DP
Accuracy:	± 2°C DP over full range
Resolution:	12-bits

Output

4-20mA loop powered:	< ± 0.25% full range error
----------------------	----------------------------

Display

Type:	Blue 128 x 64 Dot LCD Graphics display with LED backlight.
-------	--

Keyboard:

Type:	5-key metal dome tactile membrane keyboard
-------	--

Sensor

Operating Principle:	Ultra High Capacitance AL ₂ O ₃ Sensor
----------------------	--

Temperature

Operating Temperature:	-20°C to +50°C
Storage Temperature:	-20°C to +60°C

Serial Communications (logging version)

Type:	RS485
Data Format:	1 Start bit, 1 Stop bit, No Parity and No hardware handshaking
Baud Rate:	9600
No of Addresses:	32

Power Supply

Supply Voltage:	100-240VAC, 50-60Hz, 400mA
Output:	6VDC, 15W

Battery

Cell:	3.6V Li-Polymer 750mAh capacity
Charging:	Full Charge in 14 hours. <u>Only use the Charger supplied with SADPminiEx</u>
Capacity	Minimum of 70hrs* on full charged battery

Environmental

Approvals:	CE
EMC:	Certified to BS EN 61326-1
ATEX	Certified to BS EN 60079-0 BS EN 60079-11 BS EN 60079-26

Physical

Weight:	1.1kg (2.4lbs)
Dimension (W,H,D)	97 x 112 x 202mm (3.82" x 4.41" x 7.95")

‘*’ Battery capacity is quoted at room temperature. The battery capacity will degrade as the ambient working temperature falls.

