

Model P35

Portable SF₆ Dewpoint Analyser

Ranges available between -80°C to 0°C (-112°F to +32°F) Td.

Model P35 is a fully self-contained portable hygrometer from Alpha Moisture Systems, designed specifically for use during the assembly, commissioning and service of SF₆ gas insulated switchgear, though its features make it ideal for many other on-site applications.

Designed with the operator in mind, **Model P35** is extremely easy to use and the microprocessor technology enables accurate and reliable readings over long periods of time, ensuring the most dependable moisture measurement in both industrial and laboratory applications.



**Fully Portable SF₆ Analyser - Rugged - Fast Response -
Stable - Reliable - Accurate - Easy set up.**

Features

- Range available between -80°C to 0°C Td (-112°F to +32°F)
- Guaranteed Accuracy $\pm 2^\circ\text{C}$ Dewpoint
- User Friendly - Simple Operation
- Portable - Fully Self Contained
- Digital Indication in °C or °F
- Automatic Calibration
- Sample Flow Indication
- Quick Connect SS Fittings
- Battery or Mains/AC Operated
- Supplied with a Certificate of Calibration
- Sample Flow Control for Inlet Pressure up to 20 barg
- Desiccant Dry-Down Chamber For Rapid Measurements.

The incorporation of the **Desiccant Dry-Down Chamber** (See page 2), together with stainless steel quick connect fittings and additional components for sample flow control and indication, means that the user can be assured that an accurate reading will be made using a minimal amount of valuable SF₆ gas.

Designed to measure at atmospheric pressure, **Model P35** encompasses an overall range from -80°C to 0°C dewpoint. Precise factory calibration ensures guaranteed accuracy and reliability of operation. The instrument can be operated from a switchable mains/ac supply of 100/120V or 200/240V AC, or using self contained internal batteries.

Model P35 is supplied ready for use with batteries installed, a certificate of calibration traceable to National and International Humidity standards, two metres of stainless steel braided PTFE sampling hose and instruction manual.

Specifications

SENSOR TYPE

Aluminium Oxide Ultra High Capacitance Sensor

DISPLAY

3½ Digit LCD

RANGES

Between -80°C and 0°C Dewpoint (-112 to +32°F)

DISPLAY RESOLUTION

0.1°C Dewpoint

ACCURACY

Better than $\pm 2^\circ\text{C}$ Dewpoint. All sensors supplied with a certificate documenting factory calibration against known moisture levels, traceable to National & International Humidity Standards.

REPEATABILITY

$\pm 0.3^\circ\text{C}$ Dewpoint

OPERATING PRESSURE

Input pressure - 20 Bar, Max Sensor Pressure - 0.5 Bar

RESPONSE TIME

Typically 95% of reading within 20 seconds in normal operation.

POWER SUPPLY

Either 100-120 or 200-240 V AC switchable, or 9V DC self contained internal batteries (Six "C" type disposable batteries).

BATTERY LIFE

In excess of 150 hours during continuous operation.

ELECTROMAGNETIC COMPATIBILITY (EMC)

Complies with BS EN 61326-1

FLOW RATE

0.2 to 1 litres/minute SF6 at NTP

OPERATING CONDITIONS

Temperature : -20°C to $+50^\circ\text{C}$

Humidity : 0-98% RH, Non-condensing

Storage Temperature : -50°C to $+70^\circ\text{C}$

CONNECTIONS

Inlet : Swagelok quick-connect Stainless steel coupling

Outlet : ¼ OD Swagelok stainless steel tube fitting

SAMPLE TUBE

Stainless Steel Braided PTFE Hose

WARRANTY

1 year from date of delivery against faulty materials or workmanship.

Desiccant Dry Down Technology

The Desiccant Head Assembly

Keeping the sensor dry between tests ensures that the P35 is always ready to carry out rapid spot checks. The unique design of the Desiccant Head achieves this by surrounding the sensor with desiccant before the head is lifted for sampling.

At no time is the sensor allowed to come into contact with ambient air. The chamber is also designed so that the void space and chamber wall surfaces are purged with sample gas, before exposure of the sensor, so giving faster, more accurate and reliable results.

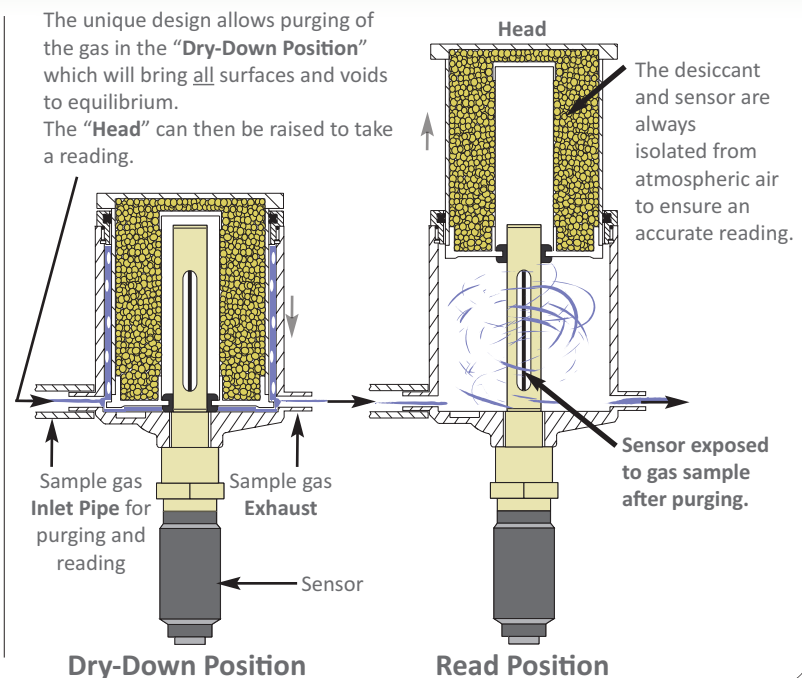

Corrosive Gases

The Sensor should not be exposed to corrosive gases (or corrosive contaminants in the main gas sample) as they would chemically attack the sensor and render it useless.

Examples of such gases are mercury (Hg), ammonia (NH₃), chlorine (Cl₂) and wet acid vapours i.e. acid vapours in gas with moisture content greater than 100ppm(v). Strong oxidising agents such as ozone (O₂) should also be prevented from coming into contact with the sensor.

Weights and Dimensions

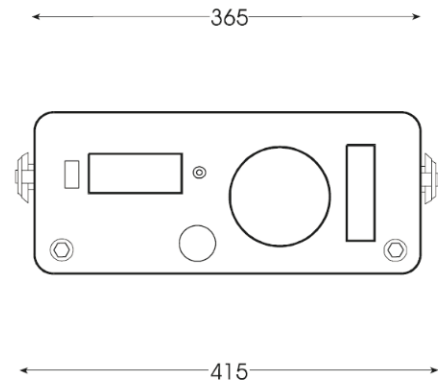
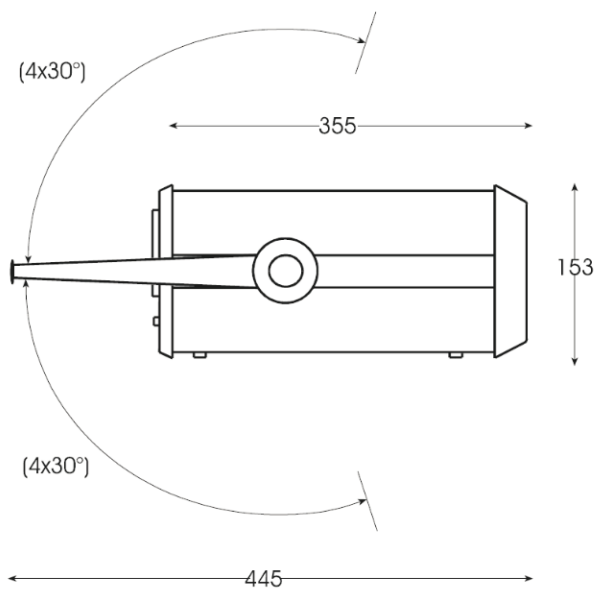
Model P35 Portable SF₆ Dewpoint Analyser

Weight unpacked - 9.4 Kgs (Nett)
Weight packed - 11.5 Kgs (Gross)

How to Order - Step 1 of 2

Select a Range Below

Model P35 + [XX]

GREY	-80 to 0°C	GY
RED	-80 to -20°C	RD
YELLOW	-60 to 0°C	YW

Example : If your requirement is for a Portable dewpoint meter with an operating range of -80°C to 0°C dewpoint then please order as : Model P35-GY

Your Model P35 includes the following parts:

- 2m of high quality stainless steel braided PTFE hose with 1/4:NPT tapered fitting and female quick connector.
- Pressure calculator and instruction manual.
- Adjustments screw driver.

Related Product

Model GCTU-PDT-PTY-S02
SF₆ Gas Collection and Transfer Unit4 in 1 SF₆ Analyser

- 4-20mA transmitter (model PDT) with accuracy to ±2°C (3.6°F). Range -60°C to +20°C dewpoint. °F or ppmv.
- SF₆ Purity Analyser (%)
- SO₂ Analyser (ppmv)
- Transfer/Pump-Back Function
- Pre-factory set and fully calibrated
- Rugged transportation case

Perfect for the Electric Utility Industry

How to Order - Step 2 of 2

Order accessories - See more at www.amsystems.co.uk

Standard Filter Unit
Order Part No. AFU



Needle Valve
Order Part No. PPE016