

Model SADPmini-Ex

Intrinsically Safe Hand-Held Automatic Dewpoint Hygrometer with Logging
Ranges available between -110°C to +20°C (-166°F to +68°F) dewpoint

Please Note: A newer version is available - See **SADPmini2-Ex**



The **Model SADPmini-Ex** Automatic Dewpoint Hygrometer is a popular global choice for measuring the Dewpoint (moisture content) in gases and dry compressed air and is perfect for mobile analysis in Hazardous Areas.

Ultra Compact - Ultra Portable - Ultra Functional -
Easy to Use - The Popular Global Choice.



Desiccant Dry Down Technology

Features

- Certified Intrinsically Safe for use in explosive atmospheres:
 -  II 1G Ex ia IIC T4 Ga (Ta = -20°C to +40°C)
 -  II 1G Ex ia IIC T3 Ga (Ta = -20°C to +50°C)
- Automatic Calibration (AutoCal)
- Various ranges available from -110°C to +20°C dewpoint
- Rechargeable battery - Over 80 hours of continuous operation on full charge
- User selectable units - °C, °F, ppm, ppm(w), ppb, g/m3, lbs/MMSCF
- “Desiccant Dry Down Assembly” for quick measurements
- RS485 serial communication and 4-20mA analogue output
- Real time graphic logging to PC (Safe area only)
- Advanced DATA logging & PC download
- Pressure correction computation
- True hand held Portable Device – weighing less than 1.2 kgs
- Robust ergonomically designed custom housing
- Fully self-contained and user friendly
- Capture and display of up to 16000 data points, with 20 user-definable TAG refs
- Non Ex also available - ask for SADPmini

Applications

- Natural gas production
- Petro chemical production
- Power stations
- Industrial process gases
- Explosive gases
- Gas cylinder testing
- Laboratory and research

Desiccant Dry Down Technology

The Desiccant Head Assembly

Keeping the sensor dry between tests ensures that the SADPmini-Ex is always ready to carry out rapid spot checks. The unique design of the Desiccant Head achieves this by surrounding the sensor with desiccant before the head is raised for sampling.

At no time is the sensor allowed to come into contact with ambient air. The chamber is also designed so that the void space and chamber wall surfaces are purged with sample gas, before exposure of the sensor, so giving faster, more accurate and reliable results.

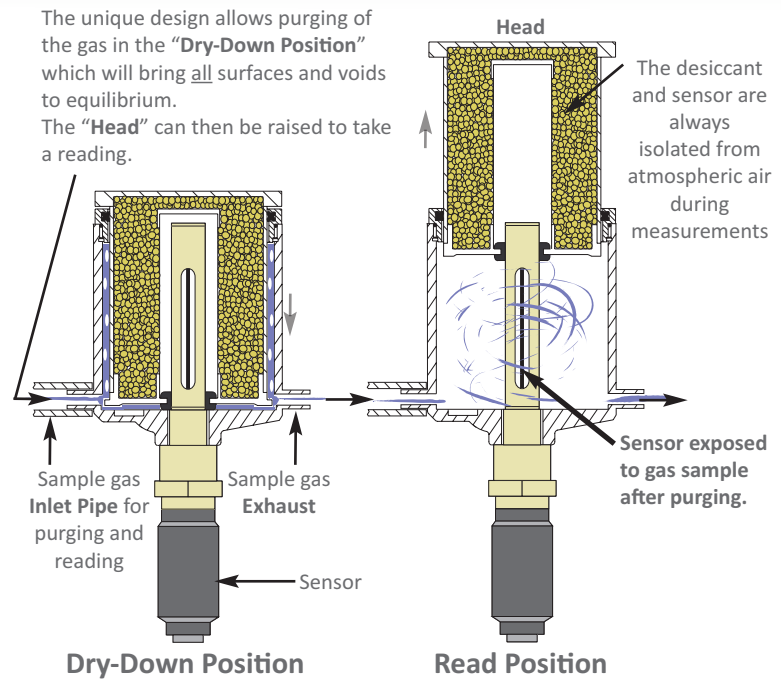

The SADPmini-Ex has been specifically designed to be Intrinsicly Safe in hazardous environments and because of this it can be used in a wide range of applications including natural gas production, petrochemical production and explosive gases.

This robust, ergonomically designed housing incorporates the moisture sensor, signal conditioning circuitry, memory management, 128 x 64 dot graphics display, 5 key membrane keyboard plus on-board rechargeable lithium-ion battery. This self contained digital unit is user friendly and eliminates the problems experienced by operators and technicians with the bulky size, weight and even analogue readouts associated with the previous generation of traditional dewpoint meters.

Dimensions

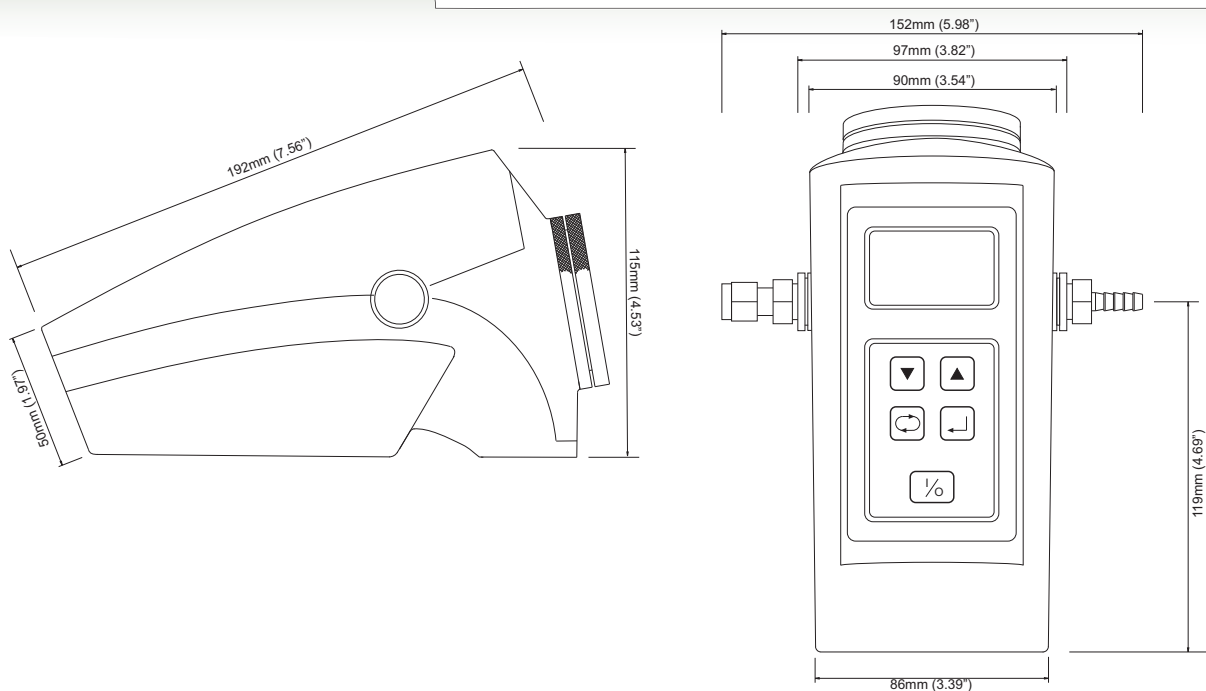

Specifications

SENSING ELEMENT: Ultra High-Capacitance Aluminium Oxide Type

RANGE IN DEW POINT:

SR: -110°C to -20°C (-166°F to -4°F)	dewpoint
PL: -100°C to 0°C (-148°F to +32°F)	dewpoint
RD: -80°C to -20°C (-112°F to -4°F)	dewpoint
GY: -80°C to 0°C (-112°F to +32°F)	dewpoint
BL: -80°C to +20°C (-112°F to +68°F)	dewpoint

DISPLAY UNITS:

°C - Degrees Centigrade dew / frost Point
 °F - Degrees Fahrenheit dew / frost Point
 ppm(v) - Parts per million (volume)
 ppb(v) - Parts per billion (volume)
 ppm(w) - Parts per million (weight)
 g/m³ - Grams per cubic metre
 lbs/MMSCF - Pounds per million standard cubic feet

DISPLAY: Blue on Green, 128 x 64 pixel, Graphical LCD with LED backlight.

SENSOR CALIBRATION ACCURACY: Better than ±2°C dewpoint. Each unit supplied with a Certificate of Calibration, traceable to National & International Standards - National Physical Laboratory (UK) / NIST (USA).

AUTOMATIC CALIBRATION: Electronic "Span Check". Performed by user following simple menu driven instructions. Can be password protected to avoid unauthorised tamper.

REPEATABILITY: Better than ±0.2°C dew point

POWER SUPPLY: Rechargeable Li-Ion Battery. Battery charger included.

BATTERY LIFE: In excess of 80 hours of continuous use on full charge at 20°C/68°F.

TIME TO FULL CHARGE: 14 hours

KEYBOARD: 5 Membrane covered, metallic dome tactile keys.

PRESSURE CORRECTION: Integral calculator to display pressure dew points. Gauge pressure can be entered in kPa, kg/cm², bar or psi.

TEMPERATURE COEFFICIENT: Temperature compensated for operating range.

GAS SAMPLE CONNECTIONS: Ports accept Swagelok® VCO type coupling (9/16" x 18 UNF). Supplied with either 6mm or 1/4" Swagelok® SS compression fitting on one side. The other side is fitted with a stainless steel push-on, "fir tree" type, hose connector

for 6mm ID tube. Each unit is supplied with a 2m length of 6mm ID PTFE tube.

ELECTRICAL CONNECTIONS: 9 Pin "D" type for 4-20mA analogue output, RS485 Serial Communications and PC interface. Separate socket for battery charger.

OPERATING TEMPERATURE: -20°C to +50°C

STORAGE TEMPERATURE & HUMIDITY: -40°C to +80°C / 95% RH Non-condensing

OPERATING PRESSURE: Atmospheric pressure.

OPERATING HUMIDITY (External): 95% RH Non-condensing

TYPICAL RESPONSE TIMES:

Wet to Dry: -10°C to -60°C - less than 120 seconds
 Dry to Wet: -110°C to -20°C - less than 20 seconds

SAMPLE FLOW RATE: Flow independent, but ideally 2 to 5 litres per minute. Max: 10 litres/min.

REPLACEMENT DESICCANT: Field Interchangeable.

SENSOR LIFE: Between 5 & 10 years - depending on application.

REPLACEMENT SENSOR: Field Interchangeable.

ELECTROMAGNETIC COMPATIBILITY (EMC): Product complies with the objectives and requirements of EMC Directive 2014/30/EU & BS EN 61326-1. See also EC Declaration of Conformity Certificate.

SECURITY: Multi level password protection.

WARM UP TIME: 10 seconds

WEATHERPROOF CLASSIFICATION: IP54 / NEMA12

WARRANTY: 1 year for faulty workmanship and defective parts.

WEIGHT: 1.2kgs (2.65lbs)

DIMENSIONS: 192 x 97 x 115 mms (7.5 x 3.8 x 4.5 inches)

MATERIALS OF CONSTRUCTION: Sensor in metal housing. Outer case custom manufactured in, stainless steel impregnated, high impact Polybutylene Terephthalate (PBT).

ACCESSORIES INCLUDED: Anti-static carrying case for use in hazardous areas. 2m PTFE Sampling pipe, Universal Battery Charger, User Manual.

Logging Specifications

As TYPE B ABOVE plus following additional specifications and features:

DATA LOGGING: 16,000 samples. Date and time stamped data, stored in chosen units of measurement for download to PC.

DATA LOCATION: 20 separate locations (Tags) can be entered (alpha-numerical) by user for data collection at pre-programmed locations.

SAMPLING RATES: User selectable (in intervals of 6 seconds) from once every 6 seconds to once a day.

DATA DISPLAY: Numerical and Graphical display of data on SADPmini-Ex screen.

REAL TIME RECORDING: Device can be programmed to monitor, record and graphically present data in real time directly to PC. ▲

SERIAL COMMUNICATIONS: RS485, baud rate 9600 - half duplex.

ANALOGUE OUTPUT: Externally powered 4-20mA loop. Linear output with unit selected. Span easily configured by user. ▲

Max. load = 50 x (V_{EXT} - 0.6) - 105

V_{EXT} = Supply voltage.

(Eg. For 24V supply, Max. load = 1065Ω)

ACCESSORIES INCLUDED: 4-20mA / RS485 Connector for analogue output and serial/USB communications. Serial or USB (Isolated / self powered) interface, with cables, for "Real Time Logging" and data download to PC. Software supplied on CD.

SYSTEM REQUIREMENT: Windows® XP or later for Serial USB connection to PC.

▲ = Safe area use only

Hazardous Area (Ex) Carrying Case

SADPmini-Ex comes with a hard wearing, padded nylon anti-static carrying case, custom manufactured with carry handle, belt loop and adjustable shoulder strap designed for use in hazardous areas.

How to Order

Model SADP_{mini-Ex} - [XX] - [X] - [XX] - [X]

RANGE IN DEW POINT = XX:

- * SR: -110°C to -20°C (-166°F to -4°F) dewpoint
- * PL: -100°C to 0°C (-148°F to +32°F) dewpoint
- * RD: -80°C to -20°C (-112°F to -4°F) dewpoint
- * GY: -80°C to 0°C (-112°F to +32°F) dewpoint
- BL: -80°C to +20°C (-112°F to +68°F) dewpoint

SAMPLE CONNECTION = X

- 4: 0.25" (1/4") - Swagelok® SS Compression Type
- 6: 6 mm - Swagelok® SS Compression Type
- 8: 0.125" (1/8") - Swagelok® SS Compression Type

EXAMPLE:

To order a SADPmini-Ex with a range of -80°C to 0°C dewpoint, 6mm pipe connection, for use in UK and to be used with a USB type PC port, order as:

Model SADP_{mini} - GY-6-UK-U

- * For optimum AutoCal operation

PC CONNECTION = X

- S: Serial (Windows®XP or later)
- U: USB (Windows®XP or later)

MAINS PLUG TYPE-
For Battery Charger = XX

- UK: Standard UK, 3 Square pin
- US: 2 Vertical Flat Blade
- EU: 2 Round Pins
- AU: 2 Oblique Flat Blades with Ground (see diagrams below)

UK Type



US Type

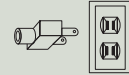

EU Type



Australian Type



SADP_{mini-Ex} comes with an Anti-Static Carrying Case for Hazardous areas as standard.

Corrosive Gases: The Sensor should not be exposed to corrosive gases (or corrosive contaminants in the gas sample) as these can chemically attack the sensor, impairing calibration accuracy and/or damaging it beyond economic repair. Examples of such gases are mercury (Hg), ammonia (NH₃), chlorine (Cl₂) etc. Strong oxidising agents such as ozone (O₃) should also be prevented from coming into contact with the sensor.

Distributor Information

Alpha Moisture Systems Limited.
Registered Office: Alpha House,
96 City Road, Bradford, BD8 8ES. UK.



CERTIFICATE No. FM35600
BS EN ISO 9001:2015

Registered in England and Wales No. 3902302
VAT Registration No. GB607207563
WEEE Producer Registration No. WEEE/EA0067TX

© Alpha Moisture Systems Ltd.

1681 SADPmini-Ex pd210923-Issue 11

Tel +44 (0) 1274 733100

Email info@amsystems.co.uk

Website amsystems.co.uk