

## Model 6020 Advanced Dewpoint Hygrometer



## User Manual

This manual should be kept with the **Model 6020**

**Please read this manual carefully**  
**from the beginning.**

**You must observe the safety information**  
**on page 3 before installation.**

**Document Reference: 1931 - Issue 8 - 21<sup>st</sup> December, 2023**



CERTIFICATE No. FM35600  
BS EN ISO 9001:2015



© Alpha Moisture Systems Ltd.



Contents

Section

- 1 General Information** ..... 2
- 2 Safety Information** ..... 3
- 3 User Interface and Controls** ..... 4
- 4 Quick Start Guide** ..... 5
- 5 Outline Specification** ..... 6
  - 5.1 Limits ..... 6
  - 5.2 Enclosure DIN Style ..... 6
- 6 Installation** ..... 7
  - 6.1 Mechanical installation into a panel ..... 7
  - 6.2 Electrical installation ..... 7-8
- 7 Installing the air/gas sampling system** ..... 9
  - 7.1 Piping installation schematic ..... 10
  - 7.2 Piping schematic component index ..... 10-11
- 8 Installing and commissioning the sensor** ..... 12
- 9 AutoCal Calibration (Sensor Ranges up to 0°C dewpoint)** ..... 13
- 10 AutoCal Calibration (Sensor Ranges up to +20°C dewpoint)** ..... 13
- 11 Entering numerical data** ..... 14-15
- 12 Hot keys** ..... 16
  - 12.1 Lock Hot keys using Panel Function ..... 16
  - 12.2 Units Hot key ..... 16
  - 12.3 Alarms Hot keys ..... 17
- 13 Using the Model 6020 Setup Menu** ..... 18
  - 13.1 Configuration Parameters ..... 19
    - 13.1.1 Choosing Moisture Units ..... 19
    - 13.1.2 Choosing Pressure Units ..... 19
    - 13.1.3 Choice of Temperature Units ..... 19
    - 13.1.4 Entry of Pressure at Sensor ..... 19
    - 13.1.5 Entry of Pressure at Display ..... 20
    - 13.1.6 Entry of Standard Pressure ..... 20
    - 13.1.7 Entry of Standard Temperature ..... 20
    - 13.1.8 Entry of Gas Type ..... 20
    - 13.1.9 Enabling and disabling the model for Natural Gas measurements ..... 20
    - 13.1.10 Enabling and disabling selection of sensor linearisation ..... 20
  - 13.2 Sensor range ..... 21
    - 13.2.1 Choosing the Sensor Range ..... 21
    - 13.2.2 Viewing Range End Points (Hi Lo) ..... 22
    - 13.2.3 Viewing linearisation data points ..... 22
    - 13.2.4 Viewing linearisation data points ..... 22-23
    - 13.2.5 Viewing the ADC values in measurement mode ..... 23
  - 13.3 Analogue output ..... 23-26
  - 13.4 Alarms ..... 27
  - 13.5 Security Features ..... 27
    - 13.5.1 Panel submenu ..... 27
    - 13.5.2 Password to control access to Setup menus ..... 27
    - 13.5.3 Password to control access to the linearised data points ..... 27
    - 13.5.4 Password to control access to Reset Command ..... 27
    - 13.5.5 Changing passwords ..... 28
  - 13.6 Reset ..... 29
  - 13.7 Digital Communications ..... 29
- 14 Monitoring the System** ..... 30
- 15 Error Messages** ..... 30
- Appendices** ..... 31
  - A Default instrument configuration ..... 32
  - B0 Setup Menu diagram ..... 33
  - B1 Configuration Submenu diagram ..... 34
  - B2 Sensor Range diagram ..... 35
  - B3 Setup Menu [Output, Alarms, Communications and Security] diagram ..... 36
  - C Communications Protocol ..... 37-38
- Contact Information** ..... 39

## 1. General information

The **Model 6020** is the next level in online dewpoint hygrometry for multi-species gases and natural gas. With powerful functions and features available that allow the user to set detailed configurations and parameters for more continuous measurement control. This makes the **Model 6020** the advanced choice with the following features and benefits:

- Large easy to read 5-digit LED display
- Four-button membrane keypad
- Six selectable engineering units
- Three hot keys to enable rapid access
- Two visual alarms LEDs
- AutoCal (Automatic Calibration) function to perform periodic auto-calibration of the sensor
- Fully-controllable linear selectable 0-20mA or 4-20mA output for process retransmission
- RS485 port for digital output
- Option for external alarms
- User-controllable password system
- AC or DC powered models available

### Component list of Model 6020 Advanced Dewpoint Hygrometer System

- Model 6020 panel mounted instrument
- Three connectors for wiring
- Ferrite Bead for power cable (supplied with AC units)
- Mounting Gasket
- 2 panel retaining screws
- Screwdriver
- User Manual
- Certificate of Calibration
- Declaration of Conformity
- Sensor Cable
- Sensor

### Optional extras

- Sensor Holder



## 2. Safety Information and Warnings

These safety instructions and guidelines **must be** followed.

The **Model 6020** is designed to be connected to hazardous electric voltages (240V).

The power supply must be protected by a **1 amp** fuse. **The Model 6020 must be earthed.**

Check to establish that all wiring and connections are not damaged. If damage is observed to any electrical wiring or damage to the apparatus they must not be connected to the power supply but returned to the supplier for rectification.

Before powering up the unit, check that the connecting plugs at the back of the unit have been wired correctly. Observe the wiring diagrams in **section 6.2, Figure 1**.

Do not connect the **Model 6020** to the power supply until it is in a permanent position.

**Risk of electric shock** - Do not open any part of the **Model 6020** whilst connected to the power supply.

Remove the power supply and isolate before any maintenance is carried out.

The power supply terminals and associated internal circuitry are isolated from all other parts of the equipment in accordance with EN61010-1 for connection to a category II supply (pollution degree2).

Any terminals or wiring connected to the input or output, which are accessible in normal operation, must only be connected to signals complying with the requirements for Safety Extra Low Voltage (SELV) circuits.

Hazardous voltages may be present on instrument terminals. The equipment must be installed by suitably qualified personnel and the instrument must be mounted in a position that provides protection behind the panel to at least IP20.

**Note:** The instrument contains no user serviceable parts.

Ignoring this safety information can result in severe personal injury and/or damage to the unit. The product specifications **must not** be exceeded at anytime as this may cause damage to the apparatus or cause risk of damage or fire.

Ensure that the **Model 6020** does not come into direct contact with water or any other liquids.

### Cleaning

**Disconnect the power supply first.** To maintain the instrument, never use harsh abrasive cleaners or solvents. Wipe the instrument only with a soft cloth slightly dampened with warm soapy water.

### Maintenance:

**Risk of damage to the Sensor** – Always ensure that the Model 6020 is “**switched off**” **before** removing or replacing a Sensor. By not doing so can result in short circuit damage to the Sensor.

### 3. User Interface and Controls

Consists of a membrane keyboard with four user input keys and also four visual indication elements or windows: the primary five character LED, a single character secondary LED for units indication, two alarm LEDs and the access cover to the **AutoCal** potentiometer.

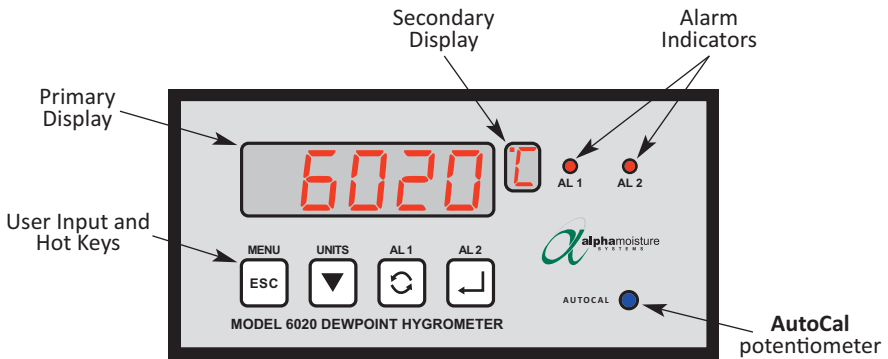

In normal operation, the **Model 6020** will display the current moisture value of the connected sensor in the Primary Display.

The engineering units are indicated in the Secondary Display.

The Alarm LED's (AL 1 & AL 2) will light **RED** whenever an alarm condition occurs and only turn off when the alarm condition clears, unless the alarms are latched.

Remote signalling of an alarm condition is provided by separate internal changeover relays that trigger at the same time as the LED's.

## 4. Quick Start Guide

**Note:** Your instrument has been calibrated by Alpha Moisture Systems to your specification.

To get started quickly there is no need to go through all the menus on the Model 6020 at this stage.

Follow these step by step instructions below for a fast set up and quick start to measuring.

1. Unpack the Control Unit and Sensor only when they are ready to install.
2. Read the safety instructions in **section 2**.
3. Make a location for the Model 6020 - For dimensions **see section 6.1**.
4. Make ready and seal all pipework for sampling.
5. Unpack and wire up the Model 6020 display unit, **see section 6.2**.  
DO NOT power up at this stage.
6. Unpack and very carefully insert the sensor into the sensor holder and connect to the Model 6020 display unit.
7. Purge the gas to be sampled through the pipework and sensor holder **see sections 7.1 and 7.2** for full details.
8. Re-check all connections and wiring - NOW power up the Model 6020.
8. The screen will now look like this for example:



9. If the display is still changing, allow this to settle before taking final reading.

**Note:** Time to settle can vary between a few minutes and several hours dependant on the condition of the sample tubing on start up. Time can be affected by for example, temperature, pressure, sample moisture content and other factors.

Take a final reading when the display is static.

10. If alarms are to be set at this stage **see section 12.3 or 13.4**.
11. To set up passwords **see section 13.5**.

## 5 Outline Specification

### 5.1 Limits

Moisture Range and Units limits		
	Upper	Lower
°C dewpoint	20.0	-130.0
°F dewpoint	68.0	-202.0
P ppm(v)	23100	0.001
g/m <sup>3</sup>	17	0.001
lb/MMSCF	1000	0.001
= ppm(w) for air	23100	0.001

} Limited to Sensor range

### Temperature Range:

Electronics	-10°C to +60°C
Sensor	-10°C to +50°C

### 5.2 Enclosure DIN Style.

Mounting flange 144 x 72 mm and enclosure extends 108 mm deep from front of mounting panel but not including cabling needs.



## 6 Installation

### 6.1 Mechanical installation into a panel

Make a cut-out in the donor panel 138.0 x 68.0 mm (DIN 43700).

The maximum panel thickness is 8mm. If an effective IP65 weatherproof seal is required, the minimum recommended panel thickness is 2.5 mm.

Pass the instrument case through the cut-out in the donor panel and attach the two retaining screws to the studs on either side of the case making use of the supplied gasket.

Tighten the retaining screws onto the back of the donor panel until the instrument is clamped securely in position. The screws must be tightened sufficiently to affect a seal between the front of the donor panel and the back of the instrument bezel, but never over tightened.

### 6.2 Electrical installation

Viewed from the rear and on the left is the moisture sensor input connector which is a panel mounted BNC. Just below it is a **cable compensation adjustment potentiometer** labelled **ZERO**.

The **ZERO** adjustment is used where long cable lengths are fitted to the instrument and, only used at the commissioning stage of the installation.

Normally, when the cable is attached and laid in the operating position, but the sensor disconnected, the instrument display should read the lowest value of the selected range. If it does not, the **ZERO** can be adjusted to compensate for any raised value induced by the cable.

Care should be taken to ensure accurate adjustment, or the accuracy of the system may be impaired. Only very small adjustments should be necessary and the procedure is as follows:

Insert the small screwdriver to engage with the ZERO potentiometer and, slowly, adjust the potentiometer until the display reads the lowest value of the selected range.

It is important to note that the display value will not indicate below the lowest value therefore care must be taken to ensure that adjustment drops as soon as the lowest value is reached.

Also see illustration **Figure 1** on the next page for wiring details.

**Figure 1**

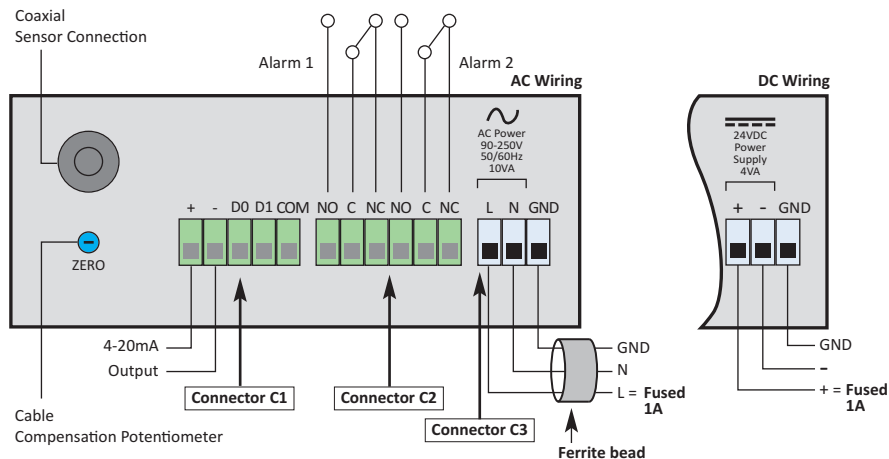

There are three banks of wiring connections points organised into groups named here as C1, C2 and C3.

**Connector C1**

Analogue Output and Digital Communications Port

- On first two pins on left is the 4-20 mA Analogue Output.
- On the last three pins is the RS485 Digital Communications port.

**Connector C2**

Alarms: Two independent SPCO volt free contacts rated 10A/240 VAC.

**Connector C3**

Power Supply: Universal 90 – 250 VAC 50/60 Hz, **or**, 24 VDC version dependant on factory set option.

**Important Notes for both AC and DC powered units.**

- The power supply to the instrument must be protected by a 1A fuse
- A local isolation switch is advisable for ease of isolation during maintenance to reduce the possibility of electric shock or damage to the instrument.
- The power supply ground GND terminal must be wired to a suitable permanent ground point.
- For AC wiring only, the supplied **ferrite bead must be installed** on the power supply cable approximately 50 mm from the connector using the tool supplied with the instrument. **See Figure 1.**
- The power supply wires are retained by screws and care should be taken to ensure that the exposed section of the wire is fully inserted and that no loose strands are exposed.
- Cables should be properly supported and segregated.

## 7 Installing the air/gas sampling system

The piping installation schematic diagram (see section 7.1) shows all components that could be used in a dry gas measurement application. Not all the items shown will be required for every installation.

Care should be taken to ensure that the sample presented to the measuring sensor is not contaminated with any component that will damage, contaminate or affect the sensor in a way that will impair the system accuracy.

It is strongly recommended that the sample should not contain particulate matter, oil or other heavy hydrocarbon condensate. If these components contaminate the sample system and/or the measuring sensor, the system response time will be lengthened, although the sensor calibration will not be effected.

**NOTE:** Corrosive Gases: The Sensor should not be exposed to corrosive gases (or corrosive contaminants in the gas sample) as these can chemically attack the sensor, impairing calibration accuracy and/or damaging it beyond economic repair. Examples of such gases are mercury (Hg), ammonia (NH<sub>3</sub>), chlorine (Cl<sub>2</sub>) etc. Strong oxidising agents such as ozone (O<sub>3</sub>) should also be prevented from coming into contact with the sensor.

The flow rate, although not critical to the sensor measurement, should be low enough to avoid abrasion to the sensor surface without being so low as to extend the system response time to an unacceptable level. In general, a flow rate of between 2 and 3 litres/min at NTP will give the right balance.

The sensor is a variable capacitor, which is directly affected by changes in partial pressure of water vapour. These changes that are proportional to the dew/frost point temperature are displayed on the instrument indicator.

The measuring sensor can be installed directly into the process line, but this does create problems with access for maintenance and calibration. It is for these reasons that we recommend that the sensor be installed in a bypass, fast loop or total loss sample system where the sensor is accessible without interrupting the main process flow line.

### 7.1 Piping installation schematic

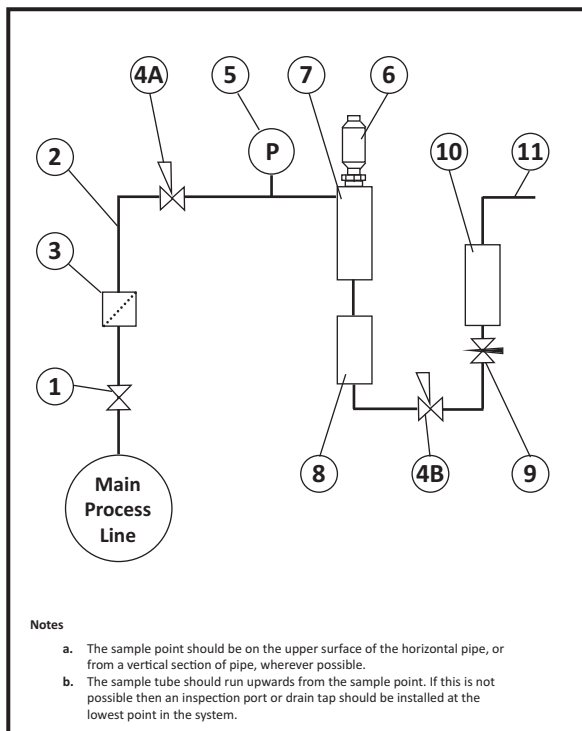

### 7.2 Piping schematic component index

- 1) Sample Isolation Valve** – This is a recommended item as it allows access to the sample system without interrupting the main process line.
- 2) Sample Tube** – This should be stainless steel for dry air or gas applications but copper or carbon steel can be used where wetter gases are to be measured. If any section of the sample tube must be flexible then PTFE should be used. In most cases, 3mm OD (1/8”) is sufficient as it provides good system response time within minimum flow. 6mm OD (1/4”) tube can be used where pressure drops across the 3mm tube are too high.
- 3) Filter Unit** – A filter unit is recommended when the samples are likely to contain particulate matter. If the air/gas sample contains heavy hydrocarbon condensate, the filter must be of the coalescing type with a drain. The filter unit should be positioned as close to the sample point as practical.

- 4) **Pressure Reduction Valve or Pressure Regulator** – If the sample is to be measured at atmospheric pressure then the valve 4A should be fitted and 4B omitted from the system. If the sample is to be measured at full line pressure and the exhaust vented to atmosphere, then valve 4B should be fitted and 4A omitted from the system. If measurements are to be taken at full line pressure and the sample is to be returned to a part of the main line or a vent, which is at a pressure higher than atmospheric, and the input to that line needs a controlled pressure, then both 4A and 4B will be required.
- 5) **Sample Pressure Gauge** – This is not a critical part of the moisture measurement but may be required if Dew/Frost point measurements are to be made at higher than atmospheric pressure.
- 6) **Measuring Sensor.**
- 7) **Sensor Holder.**
- 8) **Desiccant Chamber** – This item is required when the sampling is to be intermittent. When installed, it prevents the ingress of wet air to the sample system while the sample is not flowing, improving the response time.
- 9) **Flow Control Valve** – This can be a separate item or combined with the flow indicator.
- 10) **Flow Indicator** – The recommended sample flow is 2 to 3 litres/min at NTP.
- 11) **Sample Exhaust** – The exhaust can be vented to atmosphere or returned to the process line as discussed above.

## 8 Installing and commissioning the sensor

It is advisable to carry out an initial purge routine of the sample loop before installing the sensor. This is to remove the possibility of sensor damage on start-up.

**Note:** Before any AutoCal procedures are carried out after installation you must first set the Zero on the Cable Potentiometer sited on the rear of the Model 6020 - see section 6.2.

Refer to the sample system schematic in **section 7.1**. Open the inlet isolation valve slowly until a small flow of air/gas (at atmospheric pressure) flows through the inlet pipe work to the sensor holder, exhausting through the sensor entry port of the sensor holder.

Allow this purge to continue for about 15 to 20 minutes to remove any residual moisture from the sample pipe work and components.

Close the inlet isolation valve and install the sensor into the sensor holder. Locate and coaxial cable in positioned on the sensor.

Open the inlet valve slowly, by opening all valves after the sensor holder, allow a low-pressure purge through the whole sample system.

**Note:** If a closed by-pass loop is installed, this section of the procedure is not possible.

Set the required flows within the sample loop.

This completes the installation and commissioning, but on initial start-up, it could take several hours for the system to reach equilibrium. The Model 6020 will now indicate the dewpoint of the air/gas surrounding the sensor, and the analogue output will be giving mA signals proportional to the indicated dewpoint.

## 9 AutoCal Calibration (Sensor Ranges up to 0°C dewpoint)

The system relies on the fact that each sensor is designed to give no further increase in reading when it reaches its maximum moisture level. This means that, for instance, the Silver Spot or Red Spot sensor will read -20°C Dewpoint when it is exposed to gas at -20°C Dewpoint, but will continue to read -20°C Dewpoint when it is exposed to wetter gas. The system can therefore be calibrated very simply by exposing the sensor to anything wetter than -20°C Dewpoint and adjusting the reading to that point on the display. For the Grey Spot Sensor the maximum level is 0°C dewpoint and the same principle applies but the gas must be above 0°C.

In practice, an AutoCal is performed as follows:-

1. Ensure the Model 6020 is powered up and displaying the moisture content in °C Dewpoint.
2. Remove the sensor from the sensor holder and expose it to ambient conditions for at least 1 minute.
3. Check the Model 6020 reading. It should display the maximum level of Dew point for the instrument (i.e. -20°C for Red and 0°C for Grey).
4. If the unit is reading incorrectly then use a small screwdriver to turn the Autocal potentiometer (found on the front panel of the instrument under the knurled cap) clockwise to increase the reading (wetter) or anticlockwise to decrease it (drier).

## 10 AutoCal Calibration (Sensor Ranges up to +20°C dewpoint)

In order to calibrate a +20°C Sensors, it is necessary to measure the ambient air Dewpoint by some other method. Careful use of a sling or whirling hygrometer can achieve accurate results or a cooled mirror device can be used.

The following procedure should be used:-

1. Ensure the Model 6020 is powered up and displaying the moisture content in °C Dewpoint.
2. Remove the sensor from the sensor holder and expose it to ambient conditions for at least 1 minute.
3. Compare the reading of the Model 6020 in the ambient air, against the actual moisture level obtained by another method. Turn the Autocal potentiometer (found on the front panel of the instrument under the knurled cap) using a small screwdriver clockwise to increase the reading (wetter) or anticlockwise to decrease it (drier).

## 11 Entering numerical data

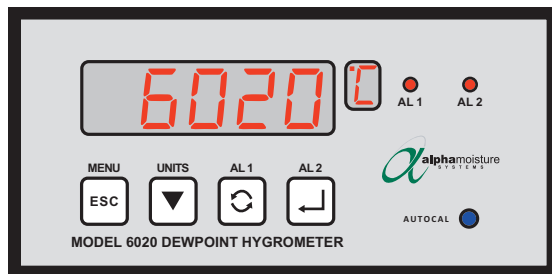

Keys	Function
	Returns the user to the previous screen, without changing any variables.
	Used to decrease the selected digit when setting a numerical variable.
	Used to select the next digit when setting a numerical variable or to scroll through the options available.
	Used to confirm a numerical variable or the selection of a chosen option.

When a numerical value has to be entered into the Model 6020 the following procedure should be used.

The right most character of the main display flashes to indicate it is active for editing. If required press the key repeatedly to select the number or sign which needs to change.

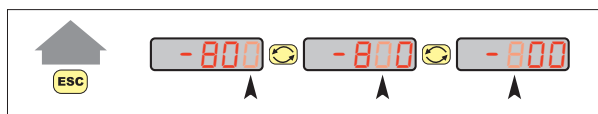

The key allows the user to leave a part of the menu without changing any settings.

Use the key to change the required number between 0 and 9.

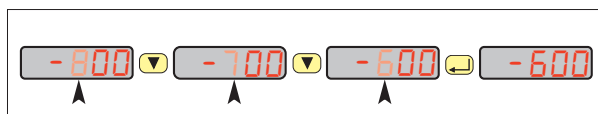

Pressing the key at any point sets the numerical value.



Continue this process until all characters are entered.

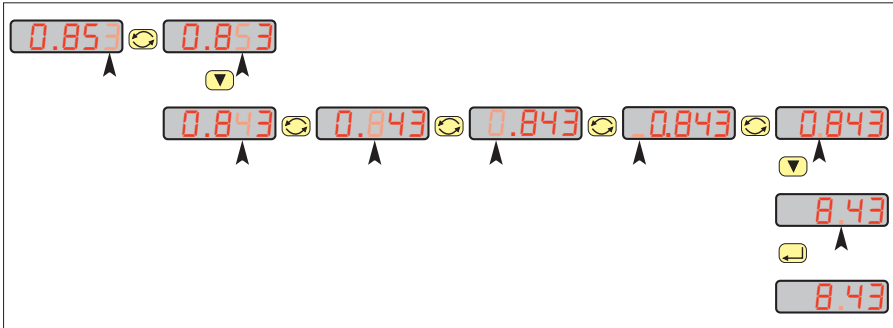

In the case of numbers associated with units which use non integer numbers such as lb/MMSCF, g/m<sup>3</sup> or ppm(w), pressing the  key repeatedly beyond the fifth character makes the decimal point (".") flashing and therefore active.

For example in order to change the alarm level from 0.853 to 8.43 g/m<sup>3</sup>



Use the  key to position the decimal point in the required position.  
Pressing the  key at any point confirms the numerical value.

The numbers associated with use of °C & °F units are fixed to 1 decimal place  
e.g. -43.8°C.



## 12 Hot keys

### 12.1 Lock Hot keys using Panel Function

There is an option to restrict the Hot keys so that Units or Alarms may only be inspected rather than adjusted using the Hot keys. If this is the case when an attempt is made to change the parameter then the user is presented with the message *rOn 14* to indicate that the parameter is “Read Only”

The Panel option allows the user to restrict the functions of the front panel Hot keys. If the ‘OFF’ option is selected, the Hot keys are RESTRICTED to “Read Only”.

**For example:**



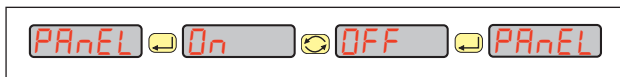

While *PARnEL* is displayed, press the  key to enter the subroutine. The main display will now display *On* or *OFF*. Use the  key to select *On* or *OFF*.



Press the  key to confirm selection.

### 12.2 Units Hot key

The  ‘Units’ Hot key allows the user to view and alter the displayed units.

To review the moisture in alternative units, press the  (Units) key for longer than 3 seconds. The main display will then show the message *Un it5*. Press the  key to select a different moisture unit in the flashing secondary display by repeatedly pressing the  key to scroll through the current moisture level in each of the moisture units. Press the  key to select the chosen moisture units and it will stop flashing.

**For example:**

To change from a ‘dewpoint C’ to a ‘dewpoint F’

While *Un it5* is displayed press the  key to enter the subroutine.

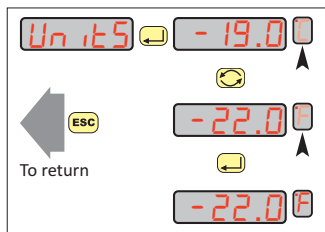

The secondary display now shows the unit type flashing.



Use the  key to scroll through to the next unit type is displayed e.g. F







Press the  key to select the new unit.

**Note:** Pressing the  key at any time escapes to the hot key function and returns to the measurement display without saving any changes.

### 12.3 Alarms Hot keys

The two alarm Hot keys 'AL 1' and 'AL 2' allow the user to review and set the Alarm trigger points.

To review the alarm trip point press the  (AL1) or  (AL2) key momentarily. The primary display will show the set trip point for 1 second before reverting back to the moisture reading.

To change the trip point press and hold the  (AL1) or  (AL2) keys for longer than 3 seconds. The main display will then show the message *AL 1* or *AL 2*. Press the  key to select Alarm in the flashing main display by repeatedly pressing the  and  keys to scroll through and adjust the alarm setting. Press the  key to select the chosen alarm setting.

### 13 Using the Model 6020 Setup Menu

To enter the Setup Menu press and hold the **ESC** key for 3 seconds. This displays the **SEtUP** message on the main display.

Press the **←** key takes the user to the top of the first item in the Setup menu structure that being either **ConF9** or **rAnGE** depending on how the instrument is configured.

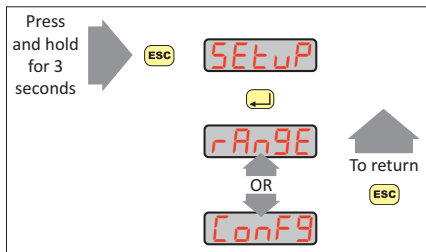

**Note 1:** If the user has set a setup password, then the user is prompted to enter the correct password before continuing on to the top level.

**Note 2:** Most of the screens within the menu have an active 10-second timeout. Therefore, if no keys are pressed within this period the unit reverts automatically to normal operation. In most cases where the 10-second timeout occurs, changes will not have been saved.

**Table 1 Setup Menu contents**

<b>Configuration</b>	Contains submenus for choosing engineering units, choice of gas types and whether sensor linearisation is employed.
<b>Sensor Range</b>	Contains submenus to choose the Range of sensor and linearisation data points.
<b>Analog output</b>	Contains submenus to allow the user to fully configure the Analog output.
<b>Alarms</b>	Contains submenus to fully control behaviour of two independent alarms.
<b>Communications</b>	Contains submenus for changing baud rate and address of the instrument’s RS485 communication port.
<b>Security</b>	Contains submenus to set up passwords to control or limit access certain features from unauthorised changes.

### 13.1 Configuration Parameters

#### 13.1.1 Choosing Moisture Units

The **Units** submenu allows the user to alter the displayed units. While **Units** is displayed press the **Enter** key to enter the submenu. The currently selected unit is displayed.

Select a different moisture unit by repeatedly pressing the **Cursor Right** key to scroll through each of the moisture units.

Press the **Enter** key to set the chosen moisture units.

**For example.**

To change from a 'dewpoint C' to a 'dewpoint F'

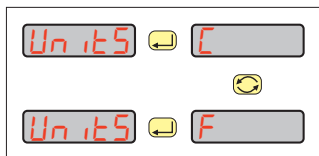

**Note:** Pressing the **ESC** key at any time reverts to the Hot key function back to the measurement display without saving any changes.

#### 13.1.2 Choosing Pressure Units

The **Unit** submenu within **SEtUP** allows the user to alter the units for the pressure parameters

The choices are:

Pascal x 10<sup>3</sup> **PA E3**

psi gauge **PS G**

bar gauge **BAR G**

#### 13.1.3 Choice of Temperature Units

The **Unit** submenu allows the user to alter the units for the temperature parameters.

The choices are:

°F **F**

°C **C**

#### 13.1.4 Entry of Pressure at Sensor

The **PSEn** submenu allows entry of pressure at sensor

### 13.1.5 Entry of Pressure at Display

*Pd .SP* allows entry of pressure at which to display the dewpoint.

### 13.1.6 Entry of Standard Pressure

*PStd* allows entry of standard pressure (Default 101.3 x 10<sup>3</sup> Pa, 0 psig, 0 barg)

### 13.1.7 Entry of Standard Temperature

*tStd* allows entry of standard temperature. (Default 60°F, 15.56°C)

### 13.1.8 Entry of Gas Type

*GRS* allows entry of type of gas at sensor for ppm(w) calculations.

Air	<i>Air</i>
Argon, Ar	<i>Ar</i>
Methane, CH <sub>4</sub>	<i>CH4</i>
Carbon Dioxide, CO <sub>2</sub>	<i>CO2</i>
Hydrogen, H <sub>2</sub>	<i>H2</i>
Nitrogen, N <sub>2</sub>	<i>N2</i>
Sulphur hexafluoride, SF <sub>6</sub>	<i>SF6</i>
Custom molar mass	<i>VALUE</i>

### 13.1.9 Enabling and disabling the model for Natural Gas measurements

*nGRS* requires a **Yes** or **No** response to turn on or off the Natural Gas correlation.

If **Yes**, then the sensor linearisation follows a modified curve defined in the Natural Gas correlation.

If **No**, the sensor follows the ideal gas linearisation.

### 13.1.10 Enabling and disabling selection of sensor linearisation

*L in* requires a **Yes** or **No** response.

If **Yes**, then the instrument linearisation follows a curve defined in the Linearisation Correction Table.

If **No**, then the instrument follows the natural response of the sensor.

### 13.2 Sensor Range

The *rAnGE* option allows the user to select the required sensor range.

#### 13.2.1 Choosing the Sensor Range

This option is used to match the Model 6020 to the sensor connected to the unit.

**For example** the change from a 'BLUE' to a 'SILVER' sensor requires that the Model 6020 *rAnGE* option *5 iL* is selected.

While *rAnGE* is displayed press the  key to enter the submenu.

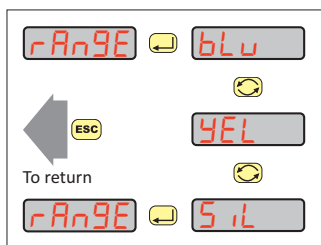

The display now shows the currently selected sensor range e.g. BLUE



Use the  key to scroll through the options until the required range is displayed e.g. SILVER

Press the  key to select the new range

**Note:** Pressing the  key at any time reverts to the *rAnGE* message prompt screen without saving any changes.

Colour		Dew Point Range (°C)	
		Minimum	Maximum
		<i>Lo</i>	<i>Hi</i>
Grey	<i>GrY</i>	-80	0
Purple	<i>Pur</i>	-100	0
Red	<i>rEd</i>	-80	-20
Blue	<i>bLU</i>	-80	+20
Yellow	<i>YEL</i>	-60	0
Silver	<i>5 iL</i>	-110	-20
Purple 0	<i>Pur0</i>	-110	+20
Purple 1	<i>Pur1</i>	-100	+20
Purple 2	<i>Pur2</i>	-120	0
Purple 3	<i>Pur3</i>	-120	+20
Purple 4	<i>Pur4</i>	-130	0

**13.2.2 Viewing Range End Points (Hi Lo)**

If the Model 6020 is setup to allow a linearization curve to be entered, then pressing the  key whilst *rAnGE* message on the main display will move to a sub menu where the selected range *H i* and the curve fitting *dAtA* points can be viewed by further presses of the  key.



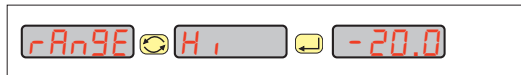

The *H i* sub menu allows the user to view the highest and lowest extremity of the currently selected range.

**For example:** to view the highest extremity of the currently selected SILVER range (-20.0°C). Press  key to view parameter(s).



**13.2.3 Viewing linearisation data points**

To view the 15 curve fitting *dAtA* points parameters requires repeated pressing of the  key and  key to return.

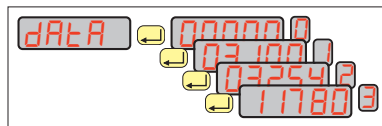





The secondary display shows the data point position number 0,1,2,3 etc. and note it indicates this in a hexadecimal numerical presentation due to the display being one character wide.

Position Number	1	2	3	4	5	6	7	8	9	10	11	12	13	14	15
Secondary Display	0	1	2	3	4	5	6	7	8	9	A	b	c	d	E

The next message prompt after the *H i* / *Lo* / *dAtA* will take you to the Password prompt (*PASS*).

**13.2.4 Editing linearisation data points**

When the *Lin* password is successfully entered the user can enter new calibration data. The user will then need to press the  key 5 times to return back to the *dAtA* sub menu. Press the  key to the data point position and enter the new data by using the  key and the  key. **Refer to Section 11 and Appendix B2.**

An invalid data entry is shown by blinking of the secondary display.



**Warning:** We strongly recommend that you record the current value **before** you enter a new value in the event that you have to re-enter the original data. **To save a new value**, press the **↵** return key repeatedly until **00000** are displayed for 1 second and the word **dAtA** is shown. At this point the new data will be saved automatically. Pressing the **ESC** escape key, or if the Model 6020 “Times Out” your new data values **will not** be saved.

**13.2.5 Viewing the ADC values in measurement mode**

Additionally an option is also enabled by this **L in** password which for the extent of the powered on state will display in measurement mode the instrument’s current analogue to digital converter count ‘ADC’ value via a **YES no** choice after the main display message prompt **Adc**. This feature may be useful for calibration laboratory work.

**13.3 Analogue output**

The Model 6020 features an analogue output port which the user may use to retransmit the moisture reading to another system. The wiring connected to this output must only be connected to signals complying with the requirements for Safety Extra Low Voltage (SELV) circuits. The output however benefits from galvanic isolation and segregation by isolated electrical circuits.

The analogue output is a current output. It is always enabled and care should be exercised therefore to ensure that during installation the two terminals are not shorted and have a load attached more than 200 Ω for optimum performance.

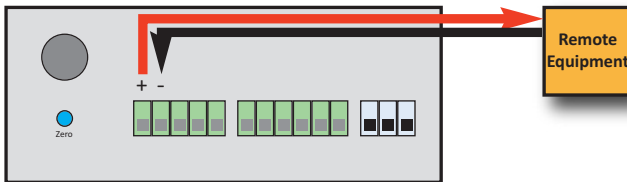

By factory default, the output is linear to match the selected units.

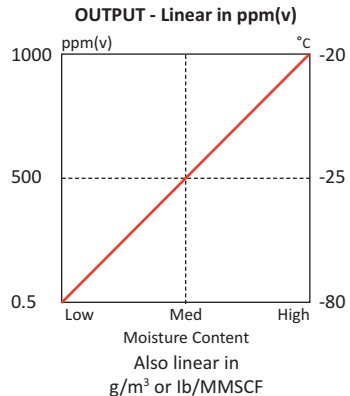
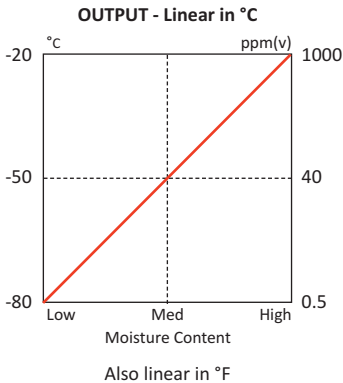

**For example:** For a blue sensor scaled from -80°C to +20°C dewpoint then the analogue output will be at its minimum when the reading is at -80°C dewpoint and at its maximum when the reading is at +20°C dewpoint.

Furthermore the factory default configuration is that the output current ranges from 4 to 20 mA.

Therefore using the above example the port will be providing 4 mA when the instrument display is at -80°C dewpoint

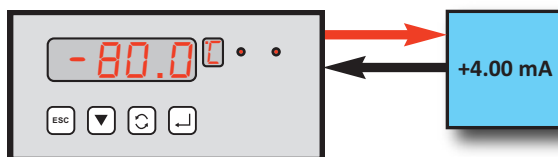

And the output provides 20 mA when the display is at +20°C dewpoint.

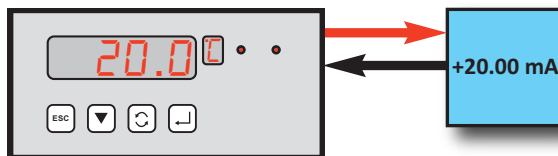

If a sensor is detected as short circuit then the current output will rise to +20.25 mA.

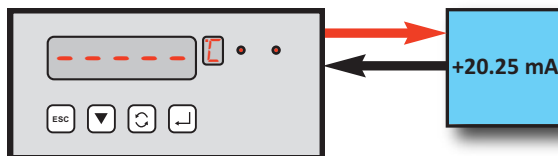

If required there is facility to change the output current calibration points at either end of the scale to attain a more focused signal.

**For example:** Moving the lower scale point from  $-80^{\circ}\text{C}$  dewpoint to  $-60^{\circ}\text{C}$  may be desirable and can be achieved by the following entry to the instrument configuration.

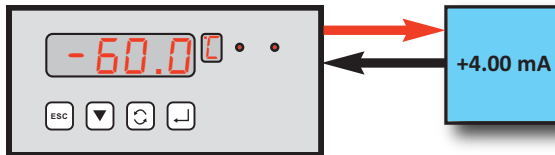
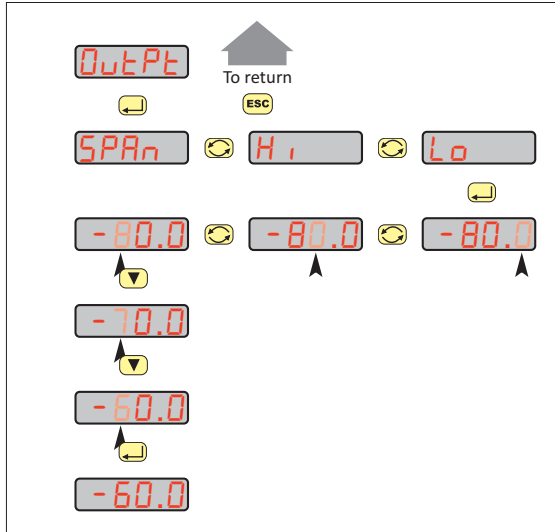

It is also possible to select a 0-20mA output range instead of the standard 4-20mA.

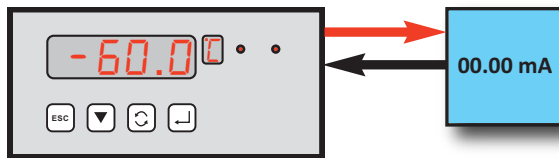
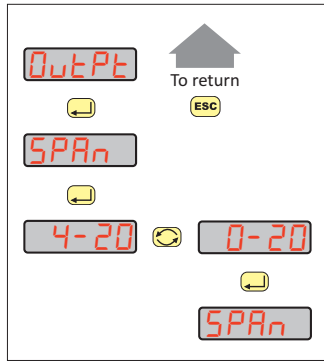



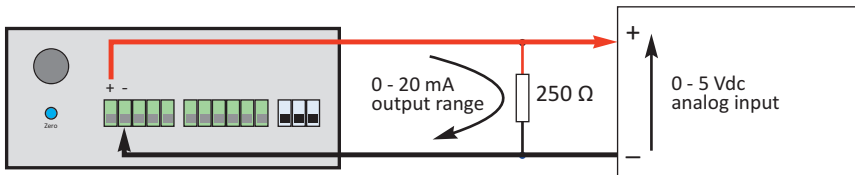

Selecting this range is useful to provide a convenient method of providing a 0-5 Vdc voltage output to the remote equipment when used in conjunction with a suitable 250  $\Omega$  resistor.



### 13.4 Alarms



The two independent alarms options (1 and 2) allow the user to setup configurable alarm events by configuring the trip points, direction of trigger, relay enable energised-on-event command, latching on-event command and hysteresis.

While **AL 1** or **AL 2** are displayed press the  key to enter the submenu. The main display indicates the trip point **SEtPt**. Use the  key to select the required function and then press the  key.

**Note:** Pressing the  key reverts back to the display **AL 1** or **AL 2** message screen.

The following functions can be performed:-

- SEtPt** Enter the alarm set point.
- tYPE** Select if the alarm is to activate on a rising signal **H i**, falling signal **Lo** or **OFF**.
- rELAY** Select if the relays are Energised **En** or de-energised **dE-En**
- LAtch** Set if the alarm is Latch **YES** or not latching **no**.
- HYSt** Enter the hysteresis value.



**Note:** Pressing the  key sets any of the alarm parameter, will not revert to the previous value even if the 10 second timeout occurs or the  key.

### 13.5 Security Features

There are options to secure features and settings .

#### 13.5.1 Panel Submenu.

The **PAneL** option allows the user to restrict the functions of the front panel Hot keys. If the **on** option is selected, the Hot keys are unrestricted.

While **PAneL** is displayed, press the  key to enter the submenu. The main display now displays **on** or **oFF**. Use the  key to select **on** or **oFF**. Press the  key to confirm selection.

#### 13.5.2 Password to control access to Setup menus.

The user may set a password to secure access to the **SEtUP** menus. The default password for this **0000**

#### 13.5.3 Password to control access to the linearised data points.

There is additionally a password which controls access to being able to edit the 15 data points parameters contained in **L in** submenu. The default password for this **9000**

#### 13.5.4 Password to control access to Reset Command.

The password on the **rESEt** allows the user to alter the security password used to protect the **rESEt** command and is entered on entry to reset submenu. The default password for this **9000**

### 13.5.5 Changing passwords

To change any of these passwords in the **SEtUP** menu navigate using scroll to the **PASS** feature in the **SEtUP** menu. While **PASS** is displayed press the **↵** key to enter the submenu.

Use scroll key **⤴** to select which of the three passwords (**SEtUP**, **L in** and **RESEt**) you wish to change and press return key **↵**.

The main display now indicates **0000**

**Note:** **0** is indicated on the secondary display to indicate you should be entering the current password using the **⏴**, **⏵** & **↵** keys.

**Note:** **!** is indicated on the secondary display to indicate you are entering the new password using the **⏴**, **⏵** & **↵** keys.

**Note:** The passwords used are made of four integers and does not use the “.”

**For example:** To change the password to limit access to the linearisation data points from the default **9000** to **0090**.

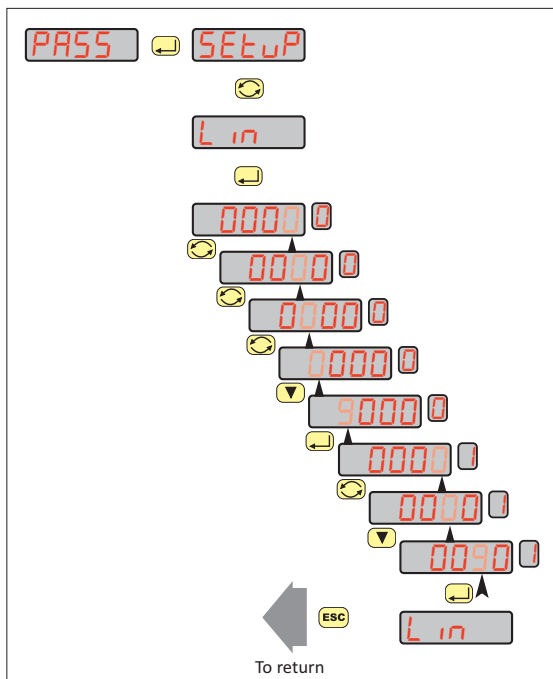

**Note:** Pressing the **ESC** key at any time will exit the submenu without committing any changes.

### 13.6 Reset

The *rESEt* submenu allows the user to reset the instrument back to the default settings.

### 13.7 Digital Communication

The *r5485* submenu allows the user to set the address and baud rate used in communicating with a PC using RS485 communications.

A RS485 interface and cable are required.

All transmission is binary and is NOT ASCII characters. 8 Bit, 1 start bit, 1 stop bit, No parity & No Flow control.

A single instrument may be connected using the universal address of 0.

Up to 32 separate instruments may be connected using addresses 1 to 32 (NOT including the universal address of 0)



The instrument is the slave and must be requested for data.

There is only one command that returns the process value in the units set in the secondary display.



Alarm state and a sensor short are returned in a 2-byte status word.



Baud rate and address are set from the front panel under *r5485* submenu.

While *r5485* is displayed press the  key to enter the submenu.

The main display now displays *Addr*. Use the  key to select either *Addr*, or *BAUD* then press the  key.

If the *Addr* option is selected the screen will display the current address value.

Use the  &  keys to enter the new value. Press the  key to set the new address. Legal addresses are 1 to 32.

**Note:** Once the  key is pressed to set the address or baud rate, that value is committed and will not revert to the previous value even if the 10 second timeout occurs or the  key is pressed.

If the *BAUD* option is selected, use the  key to select the required baud rate.

Select between: 9600, 4800, 2400 & 1200.

Press the  key to confirm selection.

**Note:** Pressing the  key reverts the instrument back to the *r5485* screen.

Refer to **Appendix C** for communications protocol.

## 14 Monitoring the System

The system is designed to operate continuously with a minimum amount of operator input.

It is, however, advisable to inspect the sample loop periodically to ensure that the required flows are being maintained.

The number and type of items employed in the sample loop will determine what, if any, routine checks should be made. If, for instance, a filter is used, the filter element should be inspected periodically and changed when necessary.

The instrument should not require any routine maintenance, but if any malfunction is suspected, it is advisable to contact your local dealer.

Should it be necessary at any time or for whatever reason, to change either the instrument or sensor, it should be noted that the instrument and sensor are completely interchangeable.

## 15 Error Messages

Message	Description
-----	Sensor or sensor cable is short-circuited. The current output will drive to 20.25 mA. Please contact your local dealer.
<i>rOn 14</i>	Attempt was made to change displayed units or Alarm Setpoint when Hot Key settings editing is prevented by PANEL submenu. Refer to <b>Section 12</b> for more information.
<i>A 10FF</i>	Attempt was made to enter alarm Hot key when alarm is switched off.
<i>Error</i>	High-priority unspecified error during value entry Limit a float of invalid subtype Set a float with invalid sign Set an invalid linearisation data point Failed save of linearisation data point Please contact Sales for advice.
<i>QuEr</i>	Attempted to adjust a value over its high range calculation limit
<i>UndEr</i>	Attempted to adjust a value under its low range calculation limit
<i>SPAn-</i>	Set loop current range with Hi Lo end points reversed
<i>SPAn0</i>	Set loop current range with Hi Lo end-points too close together



# Appendices

## Appendix A. Default instrument configuration

<b>Configuration</b>	<p>Contains submenus for choosing engineering units, choice of gas types and whether sensor linearisation is employed.</p> <p><b>Defaults are:</b></p> <ul style="list-style-type: none"> <li>• the moisture content in °C dewpoint</li> <li>• the ppm(w) calculations use the gas type as Air</li> <li>• the model for natural gas is disabled</li> <li>• the pressure units are bar g</li> <li>• the temperature units are °C</li> <li>• sensor linearisation data points are enabled</li> <li>• the standard temperature and pressures are reset to 15.56°C (60°F) and 0 barg</li> </ul>
<b>Sensor Range</b>	<p>Contains submenus to choose the range of sensor and entry of linearisation data points.</p> <p><b>Defaults are:</b></p> <ul style="list-style-type: none"> <li>• The sensor range is GREY</li> <li>• The viewing of the instrument's internal ACU readings are not enabled.</li> </ul>
<b>Analog output</b>	<p>Contains submenus to allow the user to fully configure the analog output.</p> <p><b>Defaults are:</b></p> <ul style="list-style-type: none"> <li>• Output range is set to 4-20mA</li> <li>• Output range is set to the full span of the selected moisture range e.g. 4 mA = -80°C and 20 mA = 0°C for GREY sensor range.</li> </ul>
<b>Alarms</b>	<p>Contains submenus to fully control behaviour of two independent alarms.</p> <p><b>Defaults are:</b></p> <ul style="list-style-type: none"> <li>• Both alarms setpoints are set to 0°C</li> <li>• Both alarms are set to trigger when rising above the upper limit.</li> <li>• The relays are de-energised in a non event state</li> <li>• The alarms events are not latching</li> <li>• The alarm hysteresis is set to 0.1°C or the equivalent in other units</li> </ul>
<b>Communications</b>	<p>Contains submenus for changing baud rate and address of the instrument's RS485 communication port.</p> <p><b>Defaults are:</b></p> <ul style="list-style-type: none"> <li>• The instrument will communicate with a baud rate of 9600.</li> <li>• The address will be 00.</li> </ul>
<b>Security</b>	<p>Contains submenus to set up passwords to control or limit access certain features from unauthorised changes.</p> <p><b>Defaults are:</b></p> <ul style="list-style-type: none"> <li>• The setup password is reset to 0000 and as such is not requested unless changed.</li> <li>• Other security password codes are defaulted (and on a reset set) to 9000.</li> <li>• Panel submenu is enabled allowing changes via hot keys</li> </ul>

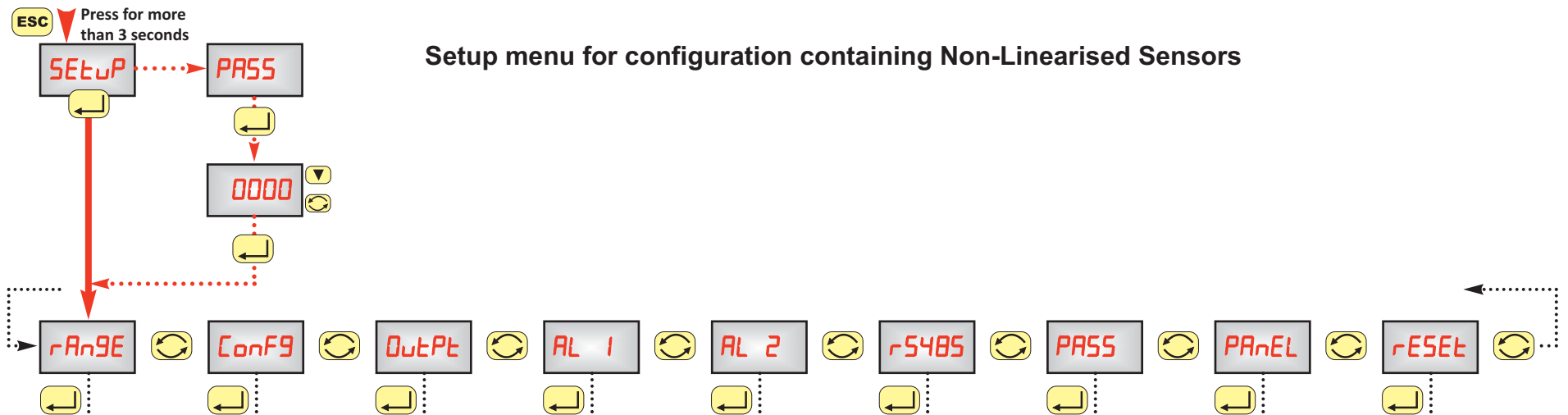
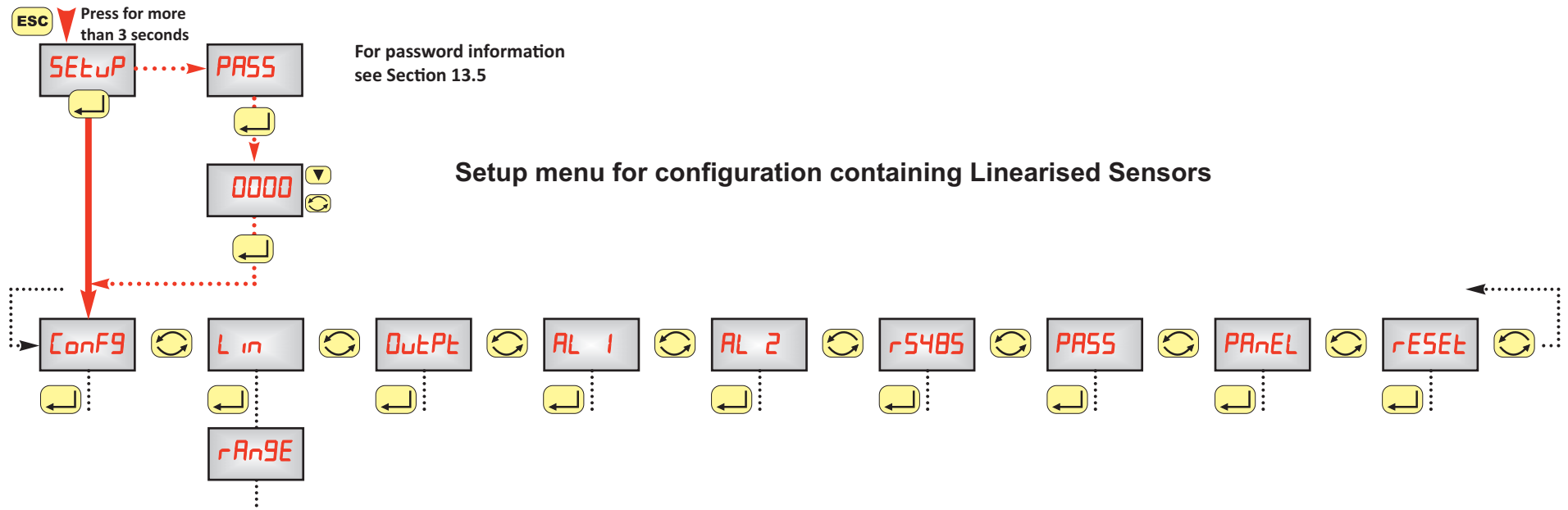

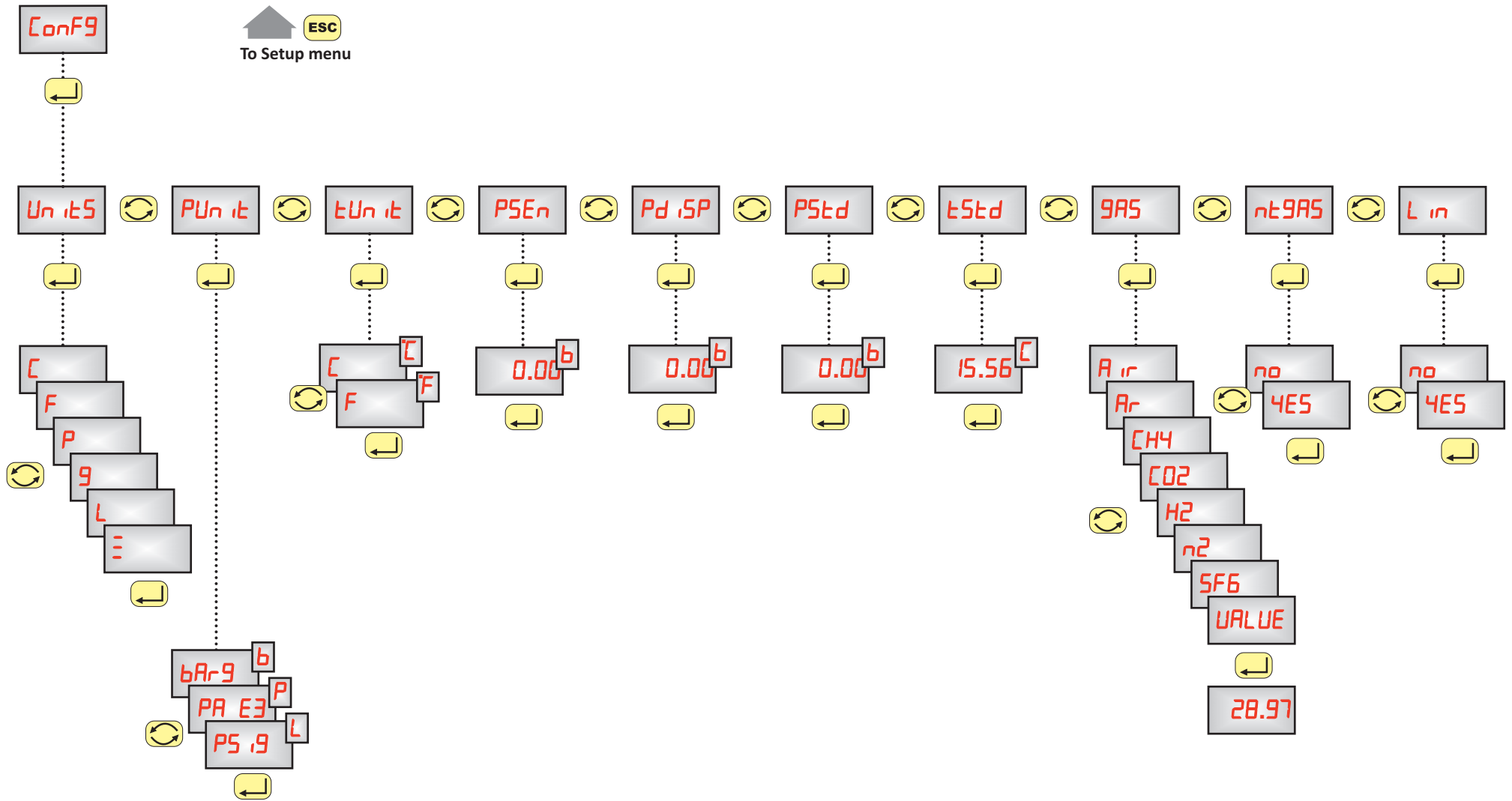

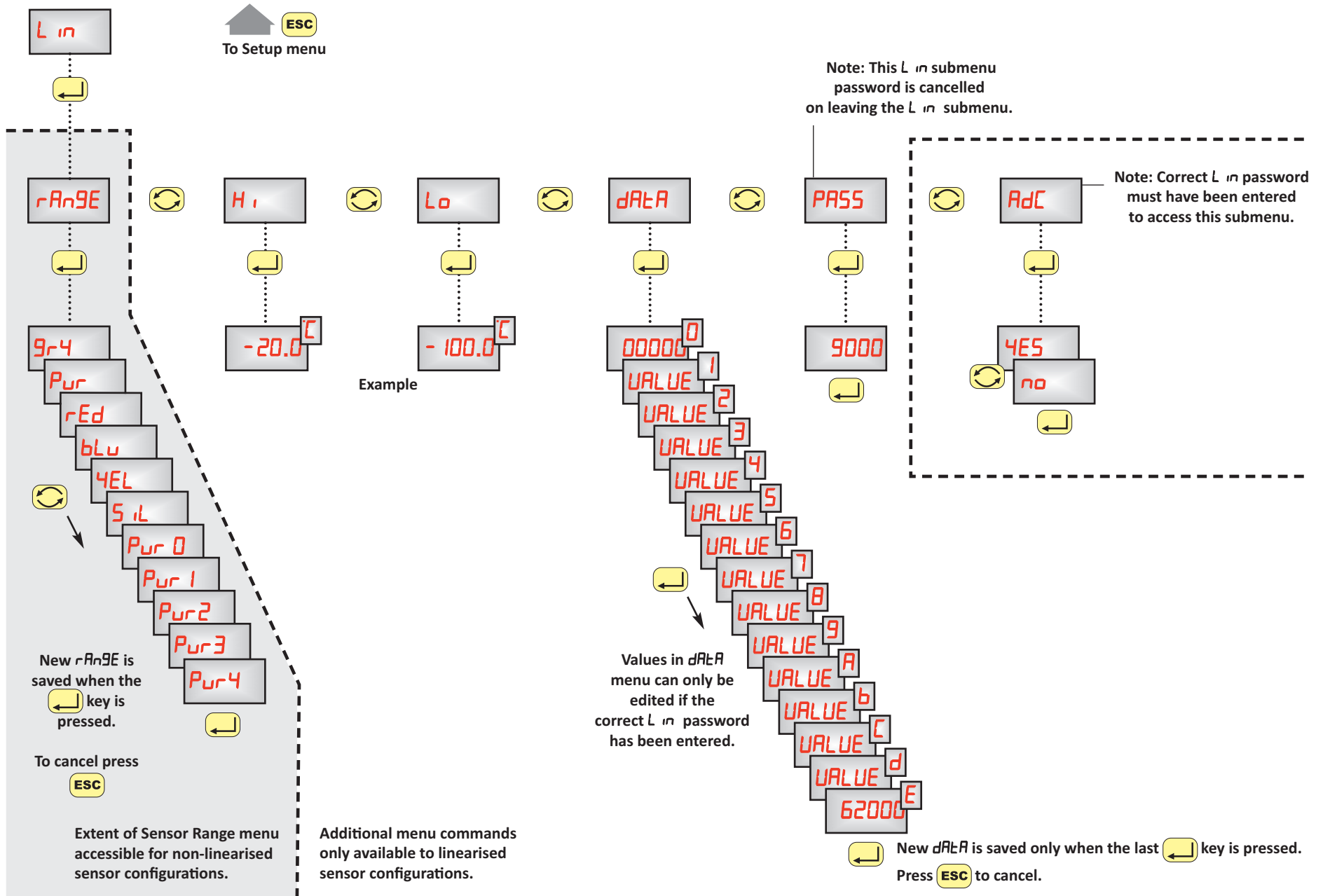

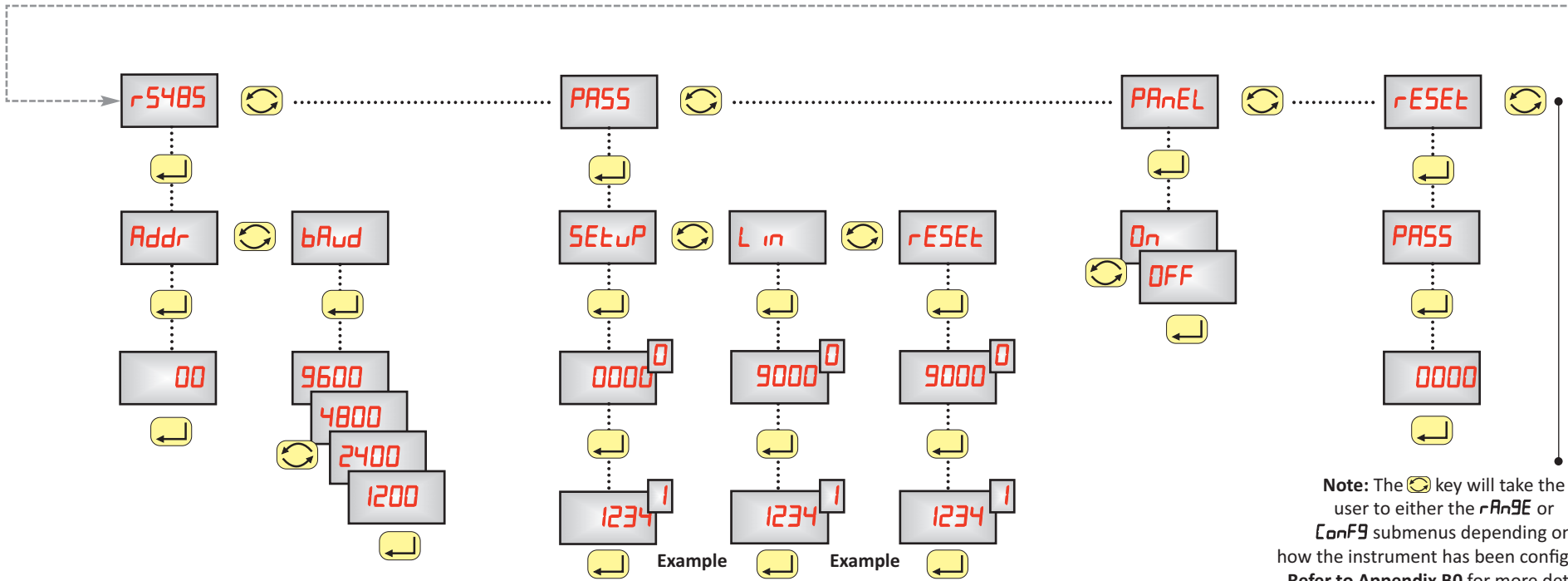
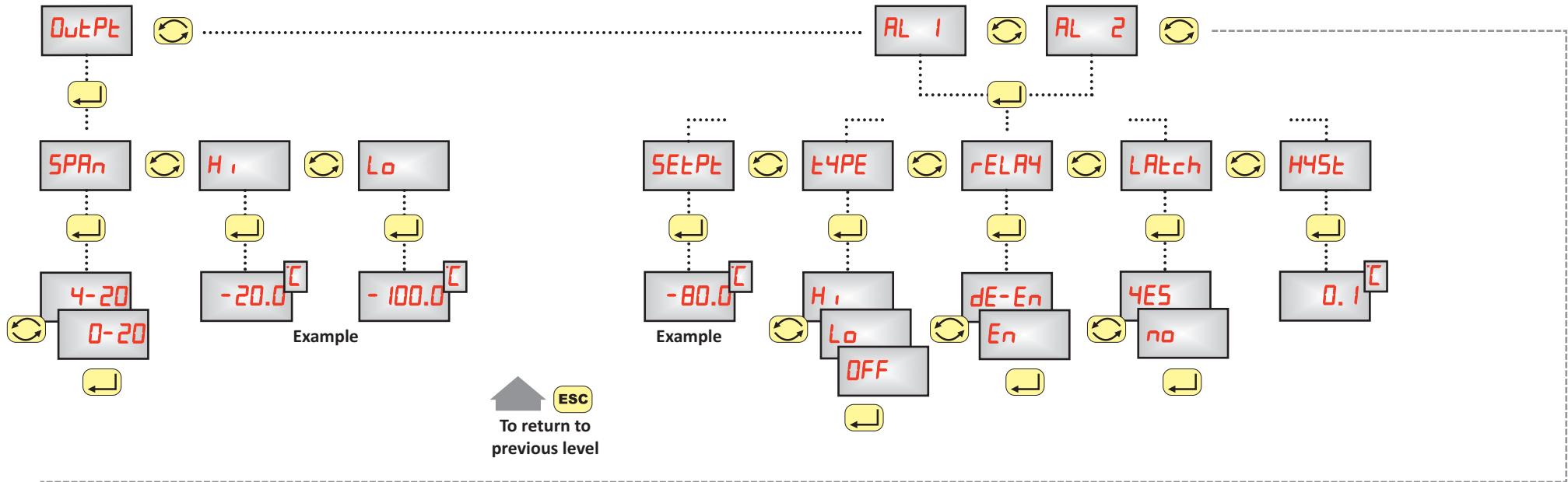

**Note:** The key will take the user to either the **rAnSE** or **ConF9** submenus depending on how the instrument has been configured. Refer to Appendix B0 for more details.

### Appendix C. Communications Protocol

RS485 REQUEST Protocol (as seen by Model 6020)		
Byte	Description	
0, first	Preamble	255
1		255
2		255
3		255
4		255
5	Master-to-Slave	2
6	Address	0 to 32
7	Command	24
8	Data Length	1
9	Data Bytes	0
10, last	Checksum	27 8-bit arithmetic XOR of byte 5 onwards

RS485 REPLY Protocol (as seen by Model 6020)		
Byte	Description	
0, first	Preamble	255
1		255
2		255
3		255
4		255
5	Slave-to-Master	6
6	Return Address	(128 for Address 0) 8-bit arithmetic OR of address with 128
7	Command	24
8	Data Len	6
9	Status	bits 15 - 8
10		bits 7 - 0
11	Data	Process Value, Single Precision (4-Byte Float), IEEE 754 Format, Big-endian (first byte = msb)
12		
13		
14		
15, last	Checksum	8-bit arithmetic XOR of byte 5 onwards

REPLY Status	
Byte	Description
15, first (ms)	Not defined
14	
13	
12	
11	
10	Alarm 1: user to clear
9	Alarm 2
8	Alarm 1
7	Not defined
6	Sensor short
5	Not defined
4	
3	
2	
1	
0, last (ls)	

**Example of communication using universal of 0**

<b>Request message sent to Model 6020</b>	255
	255
	255
	255
	255
	2
	0
	24
	1
	0
	27
<b>Reply message from Model 6020</b>	255
	255
	255
	255
	255
	6
	128
	24
	6
	0
	0
<4 bytes of single float> <1 byte of checksum>	



