

Model DS1200-PDT Dewpoint Hygrometer

-40 / +30°Cdp (50bar maximum pressure)

-60 / +20°Cdp (50bar maximum pressure)



User Manual

Model DS1200-PDT - Dewpoint Hygrometer



CERTIFICATE No. FM35600
BS EN ISO 9001:2015



Model DS1200-PDT Dewpoint Hygrometer

Document Reference:
2249 - Issue 4

06/10/2023



User Manual

This is a step by step instruction manual to help you successfully set up correctly the **Model DS1200-PDT Dewpoint Hygrometer** before use. This manual should be kept with the instrument for future reference. You must observe the safety information on pages 6 and 10 before installation.

Please read this manual carefully from the start.

Index

General Overview	5
Safety Information	6
Model DS1200 Control-Display Front Arrangement	7
PDT Arrangement	7
Features of the Model DS1200-PDT	7
DS1200 Mounting	8
Installing the Instrument into a Panel	8
Wiring DS1200 Power Supply	8
PDT Transmitter Cable	8
Alarm Cable	9
Analogue Output Cable	9
DS1200 Connections	9
PDT Connections	10
Installing the Model PDT in a Air/Gas Sampling System	10-11
Piping Installation Schematic	11-12
Installing and Commissioning the Model PDT Transmitter	13
Setting the Alarm Trip Points	13
Dimensions	14
Specifications	15-16
Contact Information	17

General Overview

Thank you for purchasing the **Alpha Moisture Systems Model DS1200-PDT Dewpoint Hygrometer**.

We hope that you will agree that this instrument is easy to set up and very user friendly to operate giving you reliable and accurate measurements quickly and efficiently.

The **Model DS1200-PDT Dewpoint Hygrometer** is a global popular choice of Dewpoint Hygrometers (trace moisture analysers) that work on a basis of polymer sensors and are used for the determination of moisture in most gases in the dewpoint or RH range.

They consist of a separately installed measuring cell of high grade stainless steel (available through your local distributor or Alpha Moisture Systems where there is no distributor for your location) a Transmitter and Control-Display, that can be integrated in a Gas Handling System*, and an in-line process source.

The **Model DS1200-PDT Dewpoint Hygrometer** is installed as a single channel analyser.

For additional accessories and parts, or technical help for the **Model DS1200-PDT**, or any other Alpha Moisture Systems products, please contact your local distributor or contact Alpha Moisture Systems - see last page for details.

***Alpha Moisture Systems can manufacture to your specifications a Gas Sample System to suit your exact requirements, please contact your local distributor for more information.**

Visit our website amsystems.co.uk for more information.



Safety Information

The **DS1200-PDT** has been designed to be connected to hazardous electric voltages and must be protected by a **5amp** fused plug to the mains/AC supply.

Check to establish that all wiring and connections are not damaged. If damage is observed to any electrical wiring, connections or damage to the apparatus they **must not** be connected to the mains/AC supply but returned to your local distributor for rectification.



Warnings

Risk of electric shock - Do not open any part of the enclosures of the **Model DS1200-PDT** whilst connected to the mains/AC supply.

Do not connect the **Model DS1200-PDT** to the mains/AC supply until all other connections and pipework is secure and have been tested.

Ignoring this safety information could result in severe personal injury and/or mechanical damage to the **Model DS1200-PDT**.

The product specifications must not be exceeded at anytime, as this may cause personal injury, damage to the instrument and sensor or cause risk of fire.

Do not connect the **Model DS1200-PDT** to any other device that is not recommended in this manual.

Ensure that the **Model DS1200-PDT** does not come into direct contact with water or any other liquids. See IP/NEMA protection in the product specifications.

To avoid the risk of electric shock, risk of damage or fire, these safety instructions and guidelines must be followed. Only qualified personnel/technicians should install these units to the mains/AC supply and connecting pipework to ensure it is completely safe by testing and recording before use.

It is the responsibility of the customer to ensure safe working conditions especially working with hazardous gases and liquids. Leak tests should be carried out periodically by qualified personnel.



Safe Isolation

Switch off at the mains/AC socket and remove the plugs before any maintenance is carried out by a qualified person. Always test components with an approved voltage meter before handling to ensure it is completely dead.

YOU MUST ALSO READ THE WARNING INFORMATION ON PAGE 10.

Model DS1200 Control-Display Front Arrangement

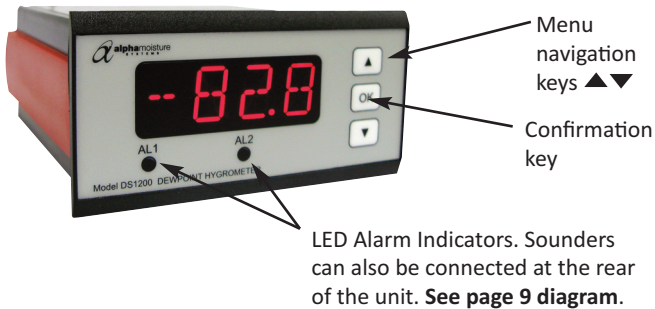

PDT Transmitter Arrangement



SUPPLIED WITH A CERTIFICATE OF CALIBRATION

See Pages 14 - 16 for dimensions, diagrams and technical specifications

Features of the Model DS1200-PDT

DS1200 Control-Display

- The **Model DS1200-PDT** is a single channel analyser.
- DS1200 has a 4-digit 14 segment LED display
- DS1200 has 2 adjustable Alarm set points and an analogue output. See pages 9 and 13.
- DS1200 has mA Output (terminals 11 and 12)
- Universal Voltage Supply (terminals 31 & 32)

PDT Transmitter

- Ranges available: -40 to +30°C or -60 to +20°C (-40 to +86°F or -76 to +68°F) Dewpoint
 - Two wire 4-20mA transmitter for continuous measurement of moisture in a process gas or compressed air
 - Reliable, accurate and easy to install
-

DS1200 Mounting

- Only technicians who are familiar with the technical terms, warnings, and instructions in the manual and who are able to follow these should connect the DS1200.
- Should there be any doubt as to the correct handling of the DS1200, please contact your local distributor.
- Mounting and connection of the DS1200 should comply with the national legislation for the mounting of electric materials, i.e. wire cross-section, protective fuse, and location.

Descriptions of Input / Output and supply connections are shown in the block diagram on **page 9** and the instrument top label.

- The maximum size of the protective fuse is **5A** and, together with the power switch, it should be easily accessible and close to the DS1200. The power switch should be marked with a label indicating it will turn OFF the voltage to the DS1200.
- To be mounted in front panels. The included rubber packing must be mounted between the panel cutout and the display front to obtain IP65 (NEMA 4) ingress protection.

Installing the Instrument into a Panel

- Make a cut-out in the donor panel 92.0/92.8 x 45.0/45.6mm (DIN 43700).
- The maximum panel thickness is 10mm and, if an effective IP65 weatherproof seal is required, the minimum recommended panel thickness is 1.6mm.
- Pass the instrument cabinet through the cut-out in the donor panel and slide the panel clamp over the instrument, from the back.
- Turn the Red panel clamp screws until the instrument is clamped in position. The screws must be tightened sufficiently to affect a seal between the front of the donor panel and the back of the instrument bezel, but never over tightened to the point of fracturing the panel clamp or instrument case.

NOTE Wires are retained by screws. Ensure that the exposed section of the wire is fully inserted and that no loose strands are exposed.

Wiring DS1200 Power Supply

- Connect the power supply cable to the 2 terminal block marked 31 and 32 no polarity.
- The power supply should be 22 to 253 VAC @ 50/60Hz or 20 to 300 VDC.

PDT Transmitter Cable

- Connect the transmitter cable to connector pins 45 and 46, ensuring that the red wire connects to pin 46. **See Diagrams on pages 9 and 10.**
Observe that the cage is securely clamped onto the bootlace ferrules on the cable provided.
- Route the sensor cable to the intended site of the sensor.

Note : - **Do not install the transmitter at this time.**
Wait until the commissioning stage as described later

Alarm Cable

- Make the appropriate connections, noting the normally open and normally closed relay contact positions.

Analogue Output Cable

- Make the appropriate connections, ensuring that the correct polarity and the maximum load specification is strictly observed.

DS1200 Connections:

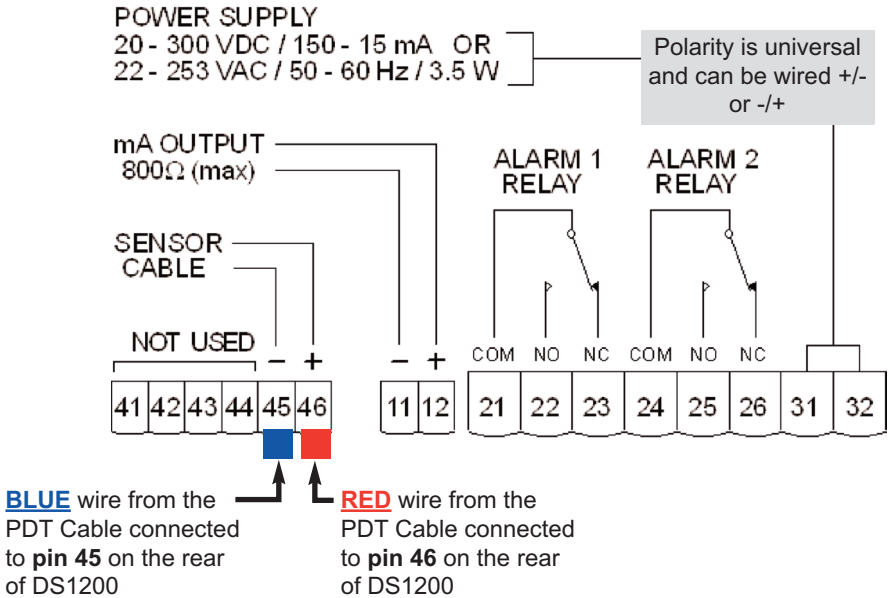

PDT Connections:

		Pin 1	Pin 2	Pin 3	Pin 4	Pin 5
PDT	Connector plug	NC	-VB	+VB	NC	NC
	Connection cable 0554.0104 (5 m) 0554.0105 (10 m)	NC	BLUE	RED	NC	NC

-VB	Negative supply voltage
+VB	Positive supply voltage 10...30 VDC smoothed
NC	Not connected

Pin 2 to Pin 45 on DS1200

Pin 3 to Pin 46 on DS1200

M12 connector plug

If no connection cable is ordered, the sensor will be supplied with a M12 connector plug. The user can connect the supply and signal cables as indicated in the connection diagram below.

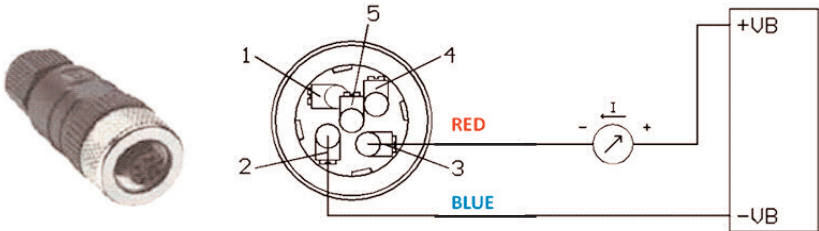

Installing the Model PDT in a Air/Gas Sampling System



Warning: Do not exceed a pressure of 50 bar.

Observe the operating ranges of the sensor. The probes are damaged if they are overheated.

Observe maximum storage and transport temperature as well as maximum operating temperature (i.e. protect the instrument from direct sunlight).

Important: Before installation, bleed compressed air systems in order to remove condensate and particles to avoid contamination.

Installing the Model PDT in a Air/Gas Sampling System - Continued

The piping installation schematic diagram below shows all components, which could be used in a dry gas measurement application although not all the items shown will be required for every installation.

The flow rate, although not critical to the sensor measurement, should be low enough to avoid abrasion to the sensor surface without being so low as to extend the system response time to an unacceptable level. In general, a flow rate of between 2 and 3 litres/minimum at NTP will give the right balance.

The sensor is a variable capacitor, which is directly affected by changes in partial pressure of water vapour. These changes are proportional to the dew/frost point temperature.

The measuring transmitter can be installed directly into the process line or ducting, but this can create problems with access for maintenance and calibration. It is for these reasons that we recommend that the transmitter be installed in a bypass, fast loop or total loss sample system where the transmitter is accessible without interrupting the main process flow line.

Piping Installation Schematic

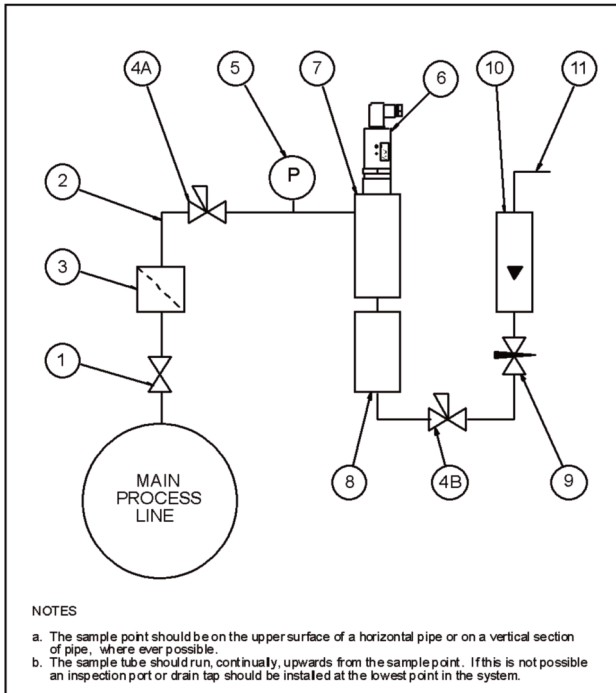

Piping Installation Schematic - Continued

- 1) **Sample Isolation Valve** - This is a recommended item as it allows access to the sample system without interrupting the main process line.
- 2) **Sample Tube** – This should be stainless steel for dry air or gas applications but copper or carbon steel can be used where wetter gases are to be measured. If any section of the sample tube must be flexible then PTFE should be used. In most cases, 3mm OD (1/8”) is sufficient as it provides good system response time within minimum flow. 6mm OD (1/4”) tube can be used where pressure drops across the 3mm tube are too high.
- 3) **Filter Unit** – A filter unit is recommended when the samples are likely to contain particulate matter. If the air/gas sample contains heavy hydrocarbon condensate, the filter must be of the coalescing type with a drain. The filter unit should be positioned as close to the sample point as practical.
- 4) **Pressure Reduction Valve or Pressure Regulator** – If the sample is to be measured at atmospheric pressure then the valve 4A should be fitted and 4B omitted from the system. If the sample is to be measured, at full line pressure and the exhaust vented to atmosphere, then valve 4B should be fitted and 4A omitted from the system. If measurements are to be taken at full line pressure and the sample is to be returned to a part of the main line or a vent, which is at a pressure higher than atmospheric, and the input to that line needs a controlled pressure then both 4A and 4B will be required.
- 5) **Sample Pressure Gauge** – This is not a critical part of the moisture measurement but may be required if Dew/Frost point measurements are to be made at higher than atmospheric pressure.
- 6) **Measuring Transmitter** – Model PDT with Connector, General Arrangement.
- 7) **Transmitter Holder** – Transmitter Holder General Arrangement.
- 8) **Desiccant Chamber** – This item is required when the sampling is to be intermittent. When installed it prevents the ingress of wet air to the sample system, while the sample is not flowing, improving the response time.
- 9) **Flow Control Valve** – This can be a separate item or combined with the flow indicator.
- 10) **Flow Indicator** – The recommended minimum sample flow is 2 to 3 litres per minute.
- 11) **Sample Exhaust** – The exhaust can be vented to atmosphere or returned to the process line as discussed above.

All additional components are available through your local distributor.

Installing and Commissioning the Model PDT Transmitter

It is advisable to carry out an initial purge of the sample loop, before installing the transmitter, in order to reduce the possibility of sensor damage on start-up.

Refer to the sample system schematic on **page 11**. Open the inlet isolation valve slowly, until a small flow of air/gas at atmospheric pressure flows through the inlet pipe work to the transmitter holder and exhausts through the sensor entry port of the transmitter holder.

Allow this purge to continue for about 15 to 20 minutes to remove any residual moisture from the sample pipe work and components.

Close the inlet isolation valve and install the transmitter into the transmitter holder. Locate and secure the cable connector in position on the transmitter. Use the locking screw in order to affect a weatherproof seal.

Open the inlet valve slowly again and, by opening all valves after the transmitter holder, allow a low-pressure purge through the whole sample system. (Note. If a closed by-pass loop is installed, this section of the procedure is not possible).

Set the required pressures and flows within the sample loop.

This completes the installation and commissioning but, on initial start-up, it could take several hours for the system to reach equilibrium.

Setting the Alarm Trip Points

To activate the quick alarm settings screen press either the "F" or "M" buttons, while the DS1200 is displaying the moisture level.

The DS1200 will flash the "F.SET" message followed by a selection menu for Alarm 1 or 2 relay. Scroll to the required alarm and press the "OK" button.

The DS1200 then displays the message "SETP" momentarily before displaying the current set point in % of scale.

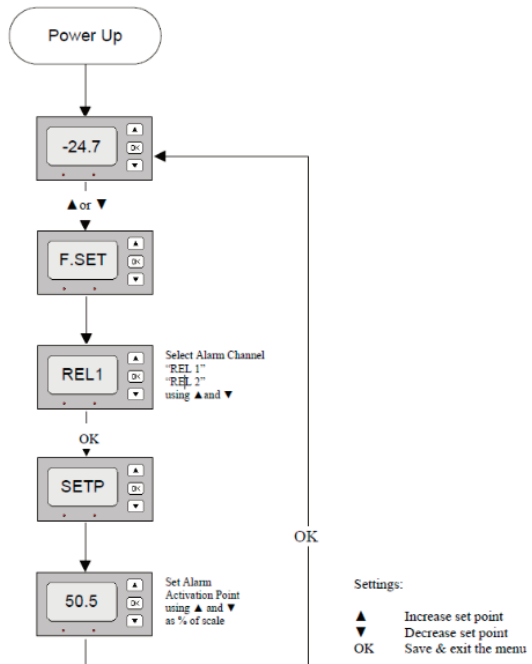

Model DS1200-PDT - Dewpoint Hygrometer

Dimensions

DS1200

FRONT

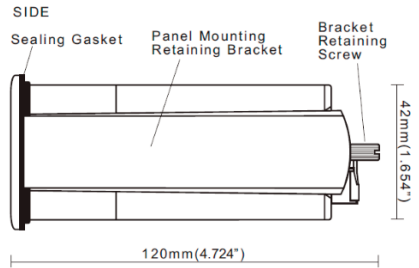
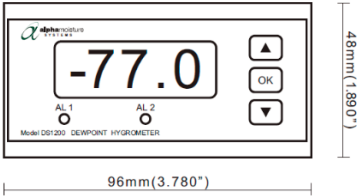

PDT Transmitter

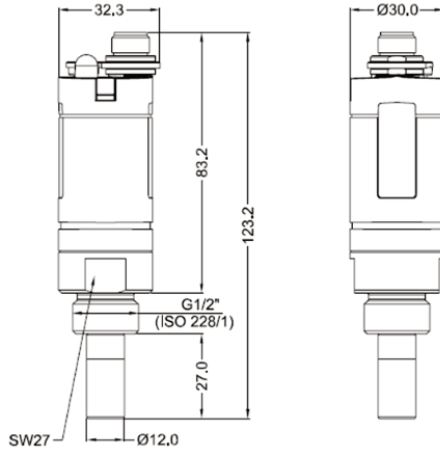

PDT Transmitter Holder Model SH-PDT Flow Through Sample Cell

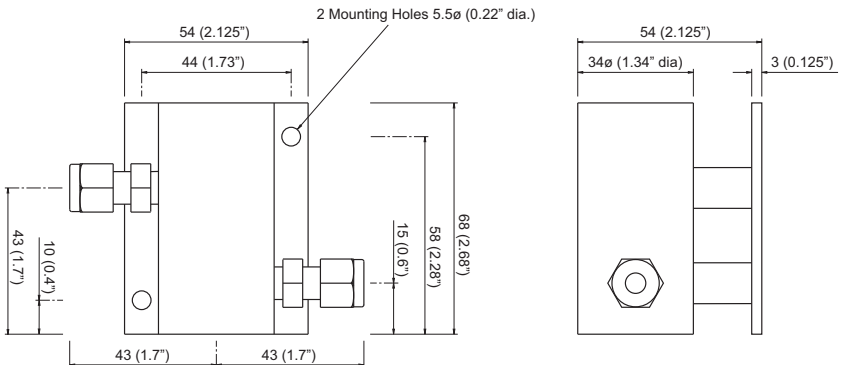

Note: The Assembly is shown with 1/4" @ OD tube fittings. The dimensions across the tube fittings will vary for all other size fittings.

Specifications

DS1200

- Temperature operating range = -20°C to +60°C (-4°F to 140°F)
- Power supply = 20 – 300 VDC, or 22 to 253 VAC 50 – 60 Hz
- 3.2W internal power consumption
- 3.5W maximum power consumption
- Isolation voltage test / operation = 2.3KVAC / 250 VAC
- Signal to noise ratio = Min 60dB (0-100kHz)
- Display Response time (0-90%, 100 to 10%) = 0.4s.
- Wire size, pin 45 & 46 (max) = 1 x 1.5mm² stranded wire
- Wire size, others (max) = 1 x 2.5mm² stranded wire
- Relative Humidity = < 95% RH
- Dimensions (HxWxD) = 48 x 96 x 120mm
- Cut out dimensions = 44.5 x 91.5mm
- Ingress Protection = (Front panel) IP65/NEMA4
- Weight = 230g
- Input
 - From Model PDT
 - Error detection = Cable loop break
- Display
 - Display Readout = PDT range
 - Scrolled error display
- Current Output
 - Programmable signal ranges = 0...20 or 4...20mADC (Factory set)
 - Load (max) 20mA / 800Ω / 16VDC
 - Load stability ≤ 0.01 % of span / 100 Ω
- Relay
 - Relay function = setpoint
 - Hysteresis 1% of range
 - Max voltage = 250 VRMS
 - Max Current = 2A /AC
 - Max AC power = 500VA
 - Max current at 24 VDC = 1A

Specifications PDT Transmitter

Output Signal	: 4 to 20mA Linear to its range.
Operating Voltage	: 10V - 30V DC.
Factory calibration	: Supplied with Certificate of Calibration traceable to NPL/NIST
Accuracy	: $\pm 2^{\circ}\text{C}$ dewpoint (NPL / NIST traceable)
Temperature compensation	: Temperature compensated for operating range.
Operating temperature	: $-30\text{...}70^{\circ}\text{C}$ (ideal $0\text{...}50^{\circ}\text{C}$)
Storage Temperature	: $-40\text{...}80^{\circ}\text{C}$
Operating Pressure	: From 1kPa (0.01 barA) to Maximum 5,000kPa (50 barA)
Sample Flow Rate	: Independent but ideally 2 to 3 litres per minute. Max: 25 litres/min.
Connection	: M12, 5-pole
EMC	: DIN EN 61326
Transmitter Enclosure	: Zinc alloy, PC, ABS
Sensor Protection	: 316 Sintered stainless steel filter - 50 micron
Weatherproof Classification	: IP65/NEMA4 when Connector mated to Transmitter.
Mechanical Connection	: G 1/2"
Mechanical Warranty	: 12 months in case of faulty workmanship and defective parts.

Specifications PDT Transmitter Holder

High Grade 316 Stainless Steel - Part Number SH-PDT

Contact Information



Head Office:

Alpha Moisture Systems

Alpha House
96 City Road
Bradford
West Yorkshire
BD8 8ES
United Kingdom

Tel: +44 (0) 1274 733 100

Email: info@amsystems.co.uk

Website: amsystems.co.uk

Office Opening Hours:

Monday - Thursday

8.30am - 5.30pm GMT

Friday

8.30am - 5.00pm

Saturday and Sunday - Closed



Distributor Information:

Notes:
