

Model PDT Dewpoint Transmitter

-40 / +30°Cdp (50bar maximum pressure)

-60 / +20°Cdp (50bar maximum pressure)



User Manual

Alpha Moisture Systems
Alpha House
96 City Road
Bradford
BD8 8ES
England

Tel: +44 1274 733 100
Email: info@amsystems.co.uk
Website: amsystems.co.uk

Model PDT Dewpoint Transmitter

User Manual



Index

1	Overview	1
2	Installing the Model PDT in a Air/Gas Sampling System	1
2.1	Piping installation Schematic.....	2
2.2	Piping Schematic Component Index.....	2
2.3	Wiring the Model PDT	4
2.4	Installing and Commissioning the Model PDT Transmitter	5
3	Model PDT Specification.....	6

1 Overview

The Model PDT Dewpoint Hygrometer is a 2-wire 4-20mA loop powered transmitter, used for continuous measurement of moisture in a process gas or compressed air, and is particularly suitable for monitoring the output of refrigerant driers. The Model PDT transmitter is factory set to output a 4-20mA signal linear for -40 to $+30^{\circ}\text{C}$ and -60 to $+20^{\circ}\text{C}$ dewpoint (%RH is available as a special order).

The Model PDT is compatible with all non-corrosive gases. For applications involving corrosive gases, please consult Alpha Moisture Systems.

Please read prior to operation!

Warning: Do not exceed a pressure of 5,000kPa (50 bar) with the standard version.

Observe the operating ranges of the sensor. The probes are damaged if they are overheated.

Observe maximum storage and transport temperature as well as maximum operating temperature (i.e. protect the instrument from direct sunlight).

Important: Before installation, bleed compressed air systems in order to remove condensate and particles to avoid contamination.

2 Installing the Model PDT in a Air/Gas Sampling System

The piping installation schematic diagram (see section 2.1) shows all components, which could be used in a dry gas measurement application although not all the items shown will be required for every installation.

The flow rate, although not critical to the sensor measurement, should be low enough to avoid abrasion to the sensor surface without being so low as to extend the system response time to an unacceptable level. In general, a flow rate of between 2 and 3 litres/min at NTP will give the right balance.

The sensor is a variable capacitor, which is directly affected by changes in partial pressure of water vapour. These changes are proportional to the dew/frost point temperature.

The measuring transmitter can be installed directly into the process line or ducting, but this can create problems with access for maintenance and calibration. It is for these reasons that we recommend that the transmitter be installed in a bypass, fast loop or total loss sample system where the transmitter is accessible without interrupting the main process flow line.

2.1 Piping installation Schematic

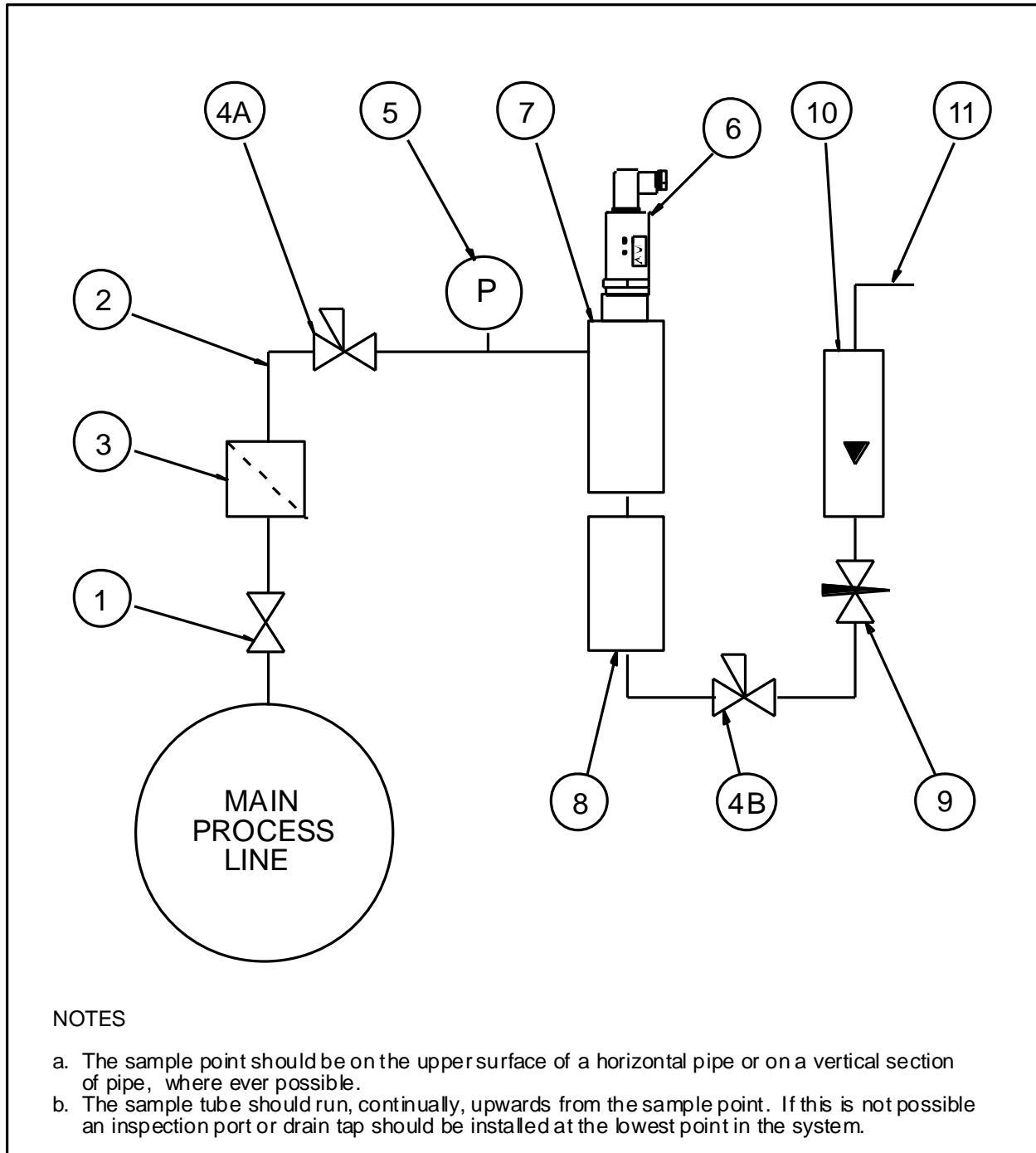

2.2 Piping Schematic Component Index

- 1) **Sample Isolation Valve** - This is a recommended item as it allows access to the sample system without interrupting the main process line.

- 2) **Sample Tube** – This should be stainless steel for dry air or gas applications but copper or carbon steel can be used where wetter gases are to be measured. If any section of the sample tube must be flexible then PTFE should be used. In most cases, 3mm OD (1/8”) is sufficient as it provides good system response time within minimum flow. 6mm OD (1/4”) tube can be used where pressure drops across the 3mm tube are too high
- 3) **Filter Unit** – A filter unit is recommended when the samples are likely to contain particulate matter. If the air/gas sample contains heavy hydrocarbon condensate, the filter must be of the coalescing type with a drain. The filter unit should be positioned as close to the sample point as practical.
- 4) **Pressure Reduction Valve or Pressure Regulator** – If the sample is to be measured at atmospheric pressure then the valve 4A should be fitted and 4B omitted from the system. If the sample is to be measured, at full line pressure and the exhaust vented to atmosphere, then valve 4B should be fitted and 4A omitted from the system. If measurements are to be taken at full line pressure and the sample is to be returned to a part of the main line or a vent, which is at a pressure higher than atmospheric, and the input to that line needs a controlled pressure then both 4A and 4B will be required.
- 5) **Sample Pressure Gauge** – This is not a critical part of the moisture measurement but may be required if Dew/Frost point measurements are to be made at higher than atmospheric pressure.
- 6) **Measuring Transmitter**, see “Appendix A – Model PDT with Connector, General Arrangement”.
- 7) **Transmitter Holder**, see “Appendix B – Transmitter Holder General Arrangement”.
- 8) **Desiccant Chamber** – This item is required when the sampling is to be intermittent. When installed it prevents the ingress of wet air to the sample system, while the sample is not flowing, improving the response time.
- 9) **Flow Control Valve** – This can be a separate item or combined with the flow indicator.
- 10) **Flow Indicator** – The recommended sample flow is 2 to 3 litres per minute.
- 11) **Sample Exhaust** – The exhaust can be vented to atmosphere or returned to the process line as discussed above.

2.3 Wiring the Model PDT

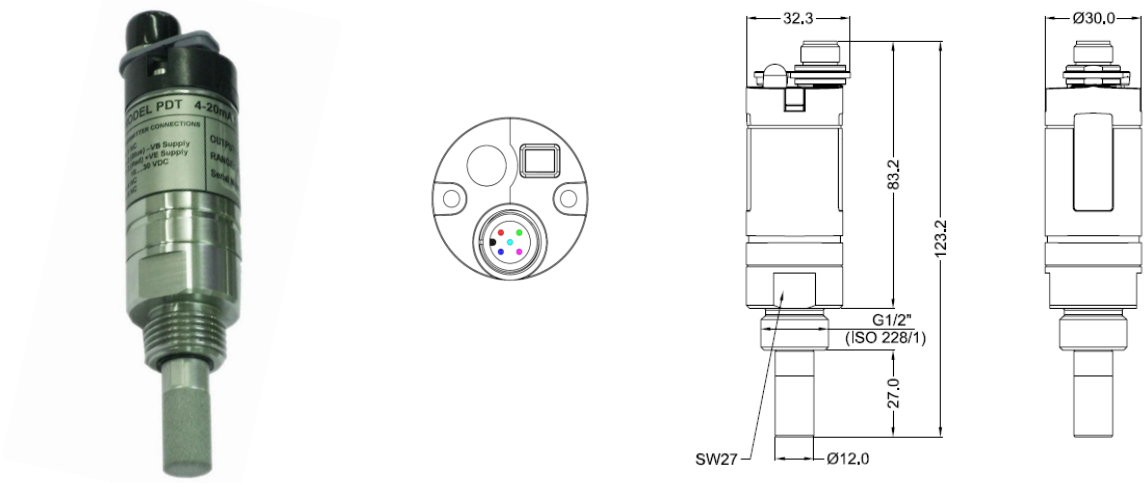

		Pin 1	Pin 2	Pin 3	Pin 4	Pin 5
PDT	Connector plug	NC	-VB	+VB	NC	NC
	Connection cable 0554.0104 (5 m) 0554.0105 (10 m)	NC	BLUE	RED	NC	NC

-VB	Negative supply voltage
+VB	Positive supply voltage 10...30 VDC smoothed
NC	Not connected

M12 connector plug

If no connection cable is ordered, the sensor will be supplied with a M12 connector plug. The user can connect the supply and signal cables as indicated in the connection diagram.

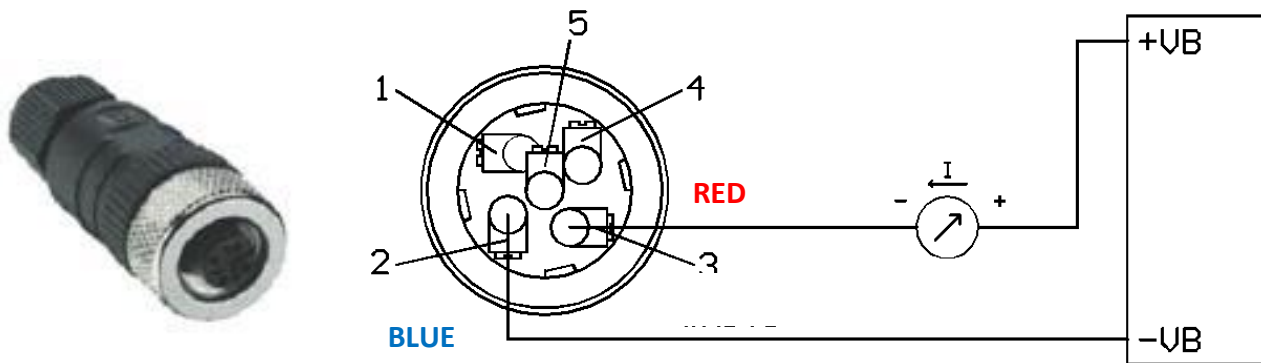

2.4 Installing and Commissioning the Model PDT Transmitter

It is advisable to carry out an initial purge of the sample loop, before installing the transmitter, in order to reduce the possibility of sensor damage on start-up.

Refer to the sample system schematic in section 2.1. Open the inlet isolation valve slowly, until a small flow of air/gas at atmospheric pressure flows through the inlet pipe work to the transmitter holder and exhausts through the sensor entry port of the transmitter holder.

Allow this purge to continue for about 15 to 20 minutes to remove any residual moisture from the sample pipe work and components.

Close the inlet isolation valve and install the transmitter into the transmitter holder. Locate and secure the cable connector in position on the transmitter. Use the locking screw in order to affect a weatherproof seal.

Open the inlet valve slowly again and, by opening all valves after the transmitter holder, allow a low-pressure purge through the whole sample system. (Note. If a closed by-pass loop is installed, this section of the procedure is not possible).

Set the required pressures and flows within the sample loop.

This completes the installation and commissioning but, on initial start-up, it could take several hours for the system to reach equilibrium.

3 Model PDT Specification

Display	:	Compatible with the 4-20mA DS1200 Dewpoint Meter.
Output Signal	:	4 to 20mA Linear
Operating Voltage	:	10V - 30V DC.
Factory calibration	:	Supplied with Certificate of Calibration traceable to NPL / NIST
Accuracy	:	± 2°C dewpoint (NPL / NIST traceable)
Temperature compensation	:	Temperature compensated for operating range.
Operating temperature	:	-30...70 °C (ideal 0...50 °C)
Storage Temperature	:	-40...80 °C
Operating Pressure	:	From 1kPa (0.01 barA) to Maximum 5,000kPa (50 barA)
Sample Flow Rate	:	Independent but ideally 2 to 5 litres per minute. Max: 25 litres/min.
Connection	:	M12, 5-pole
EMC	:	DIN EN 61326
Transmitter Enclosure	:	Zinc alloy, PC, ABS
Sensor Protection	:	316 Sintered stainless steel filter - 50 micron
Weatherproof Classification	:	IP65 when Connector mated to Transmitter.
Mechanical Connection	:	G 1/2"
Mechanical Warranty	:	12 months in case of faulty workmanship and defective parts.